

ANDY QUATTLEBAUM
OUTDOOR EDUCATION CENTER

Planning

- Anatomy of a Mass Timber Package
- Procurement, Supply Chain, Schedule Drivers

Performance

- Site Planning
- Moisture Planning and Mitigation
- UV Planning and Mitigation

Workforce Training

- Strategic Partnerships
- Training/Education
 - Resources

Holistic Costing



\$/SF



\$/SF

Sample Procurement Strategies

GC/CM Hires Turnkey Mass Timber Subcontractor	GC/CM Buys Material, Self-Performs Installation and Coordinates	GC/CM Buys Material, Subcontracts Labor and Coordinates
R I S K S P E C T R U M		
<ul style="list-style-type: none"> + Hiring experience + Single point of responsibility 	<ul style="list-style-type: none"> + Hiring experience + Single point of responsibility + Financial security of strong GC/CM 	<ul style="list-style-type: none"> + Potential added mark-up
<ul style="list-style-type: none"> – Prequalify capacity of subs – Potential added mark-up 	<ul style="list-style-type: none"> – Lack of familiarity with supply chain – Steep learning curve for coordination 	<ul style="list-style-type: none"> – Multiple layers of coordination – Prequalify capacity of sub

Anatomy of a Turnkey Mass Timber Package

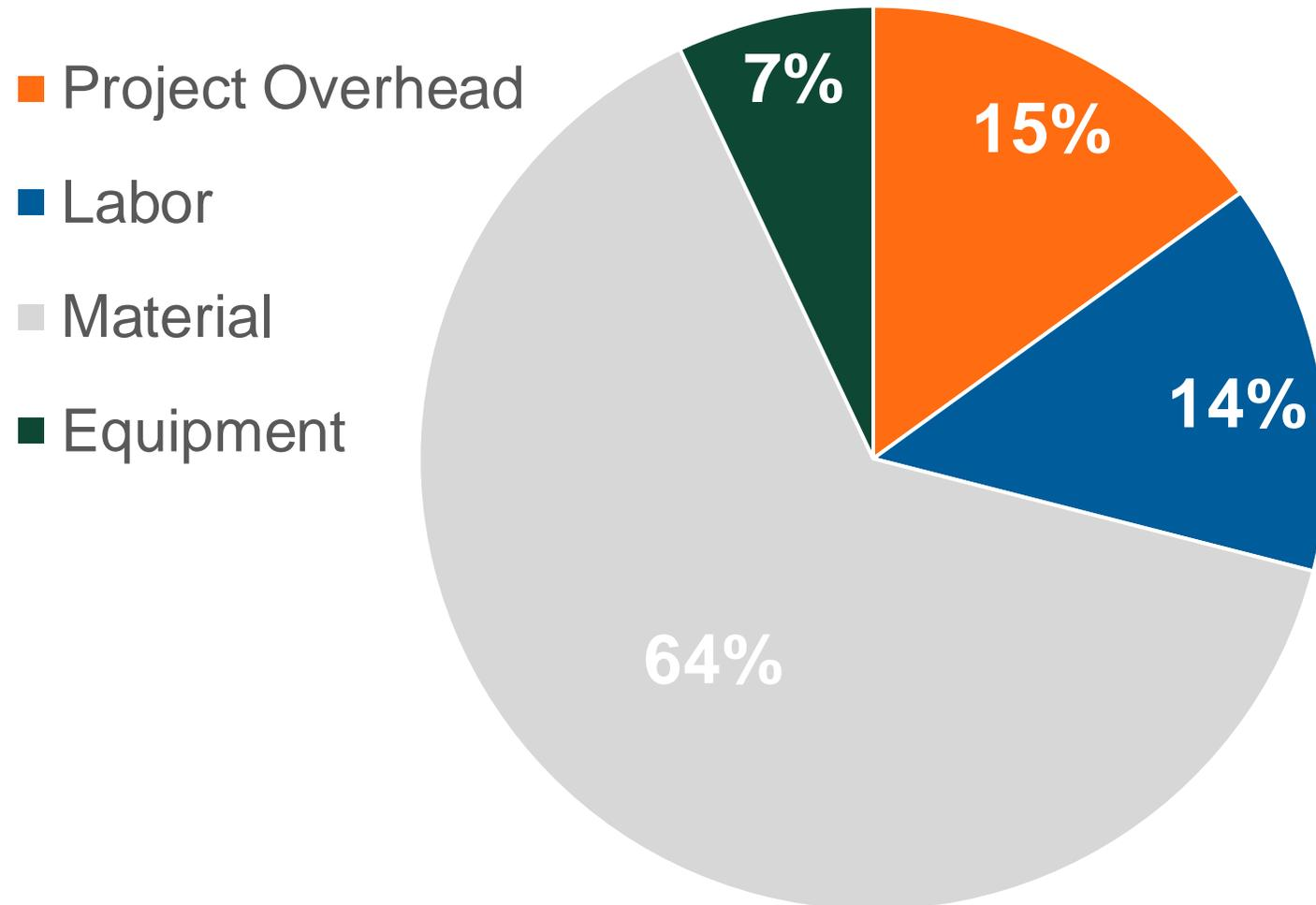

Material (Direct Cost)

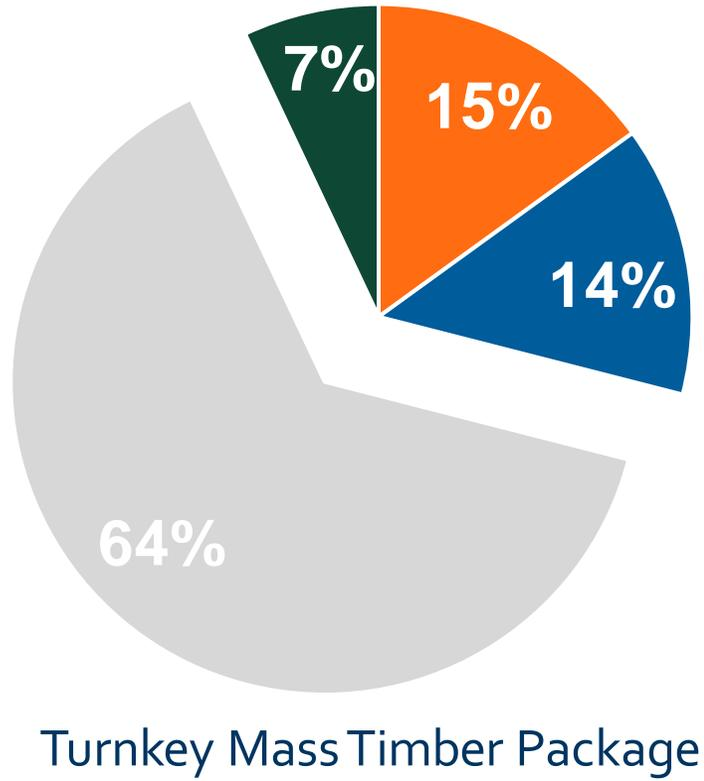

or



Mass Timber Package Costs

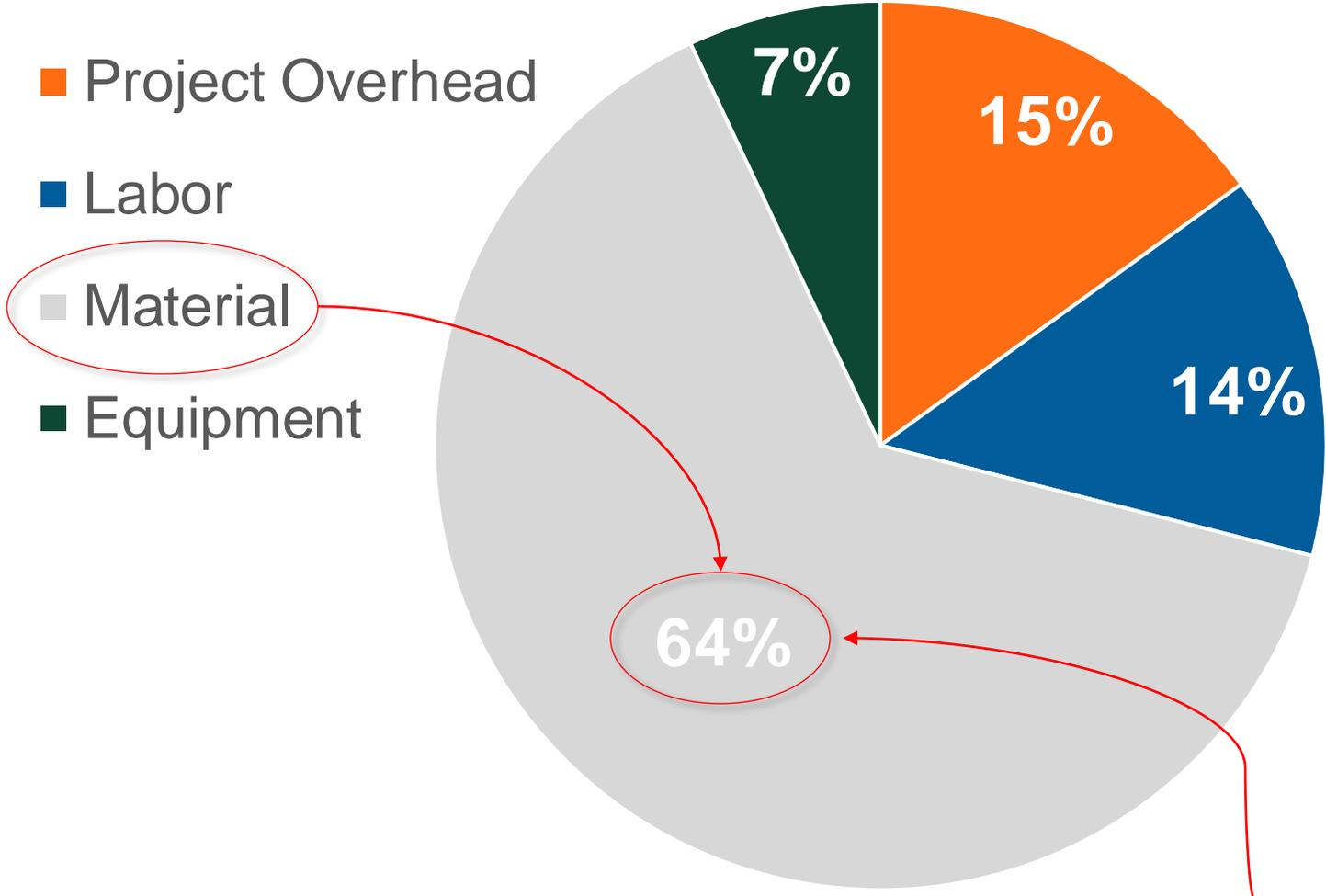

Panels are the biggest part of the biggest piece of the cost pie

Labor (Direct Cost)

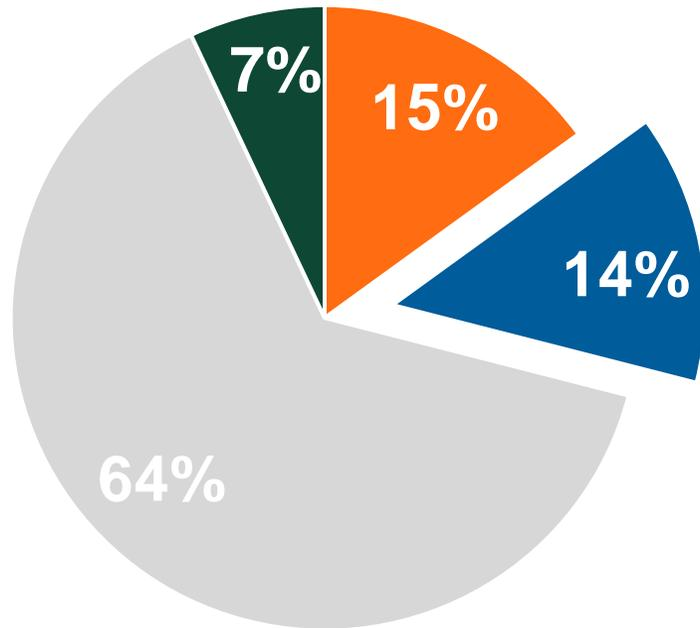

Turnkey Mass Timber Package



Photo: Swinerton

Equipment (Direct Cost)

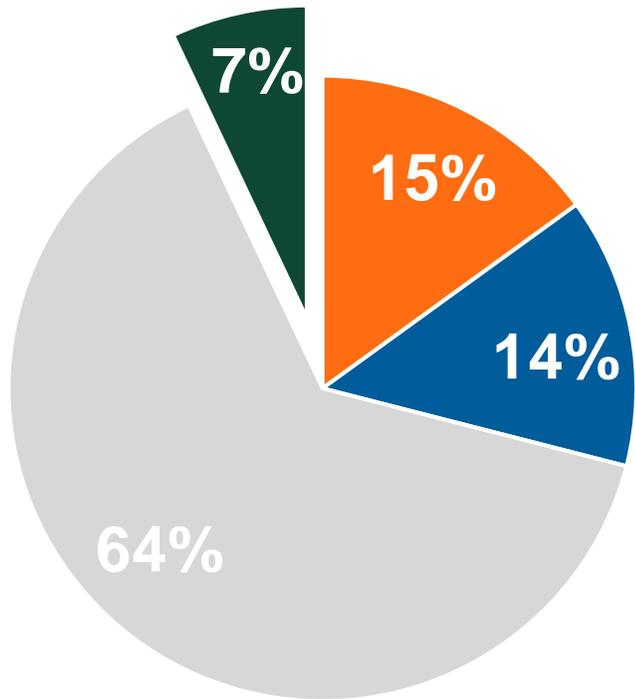

Turnkey Mass Timber Package

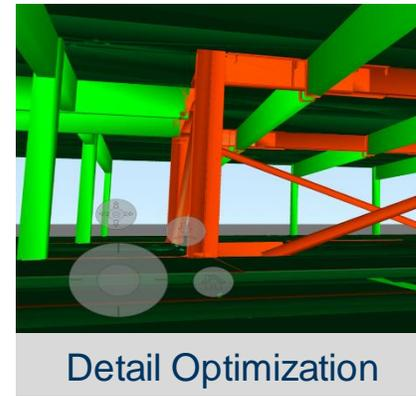
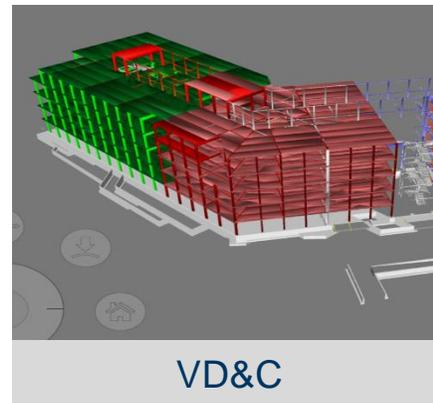
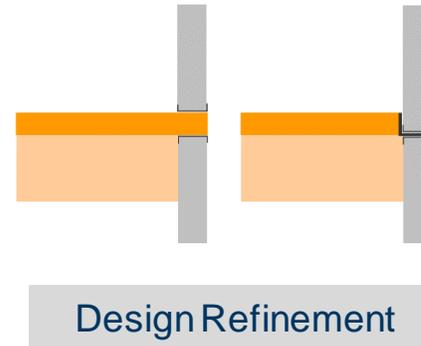
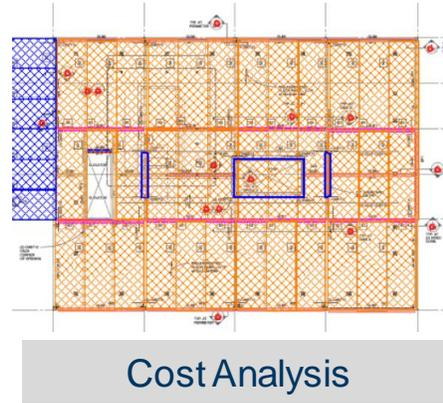
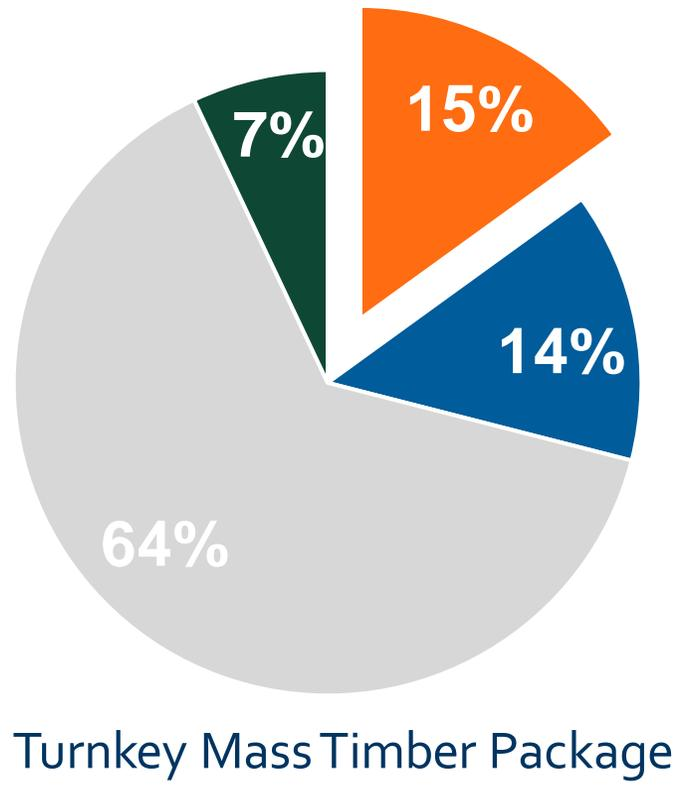

Photo: Swinerton



Photo: Alex Schreyer

Project Overhead



Photos: Swinerton

Total Project Cost Analysis

CONSIDERATIONS:

- Ceiling Treatment
- Floor Topping
- HVAC System & Route
- Foundation Size
- Material Savings
- Perimeter glazing
- Value of Time
- Completion Bonds/Insurance



Potential Cost Impacts: Design-Bid-Build Procurement

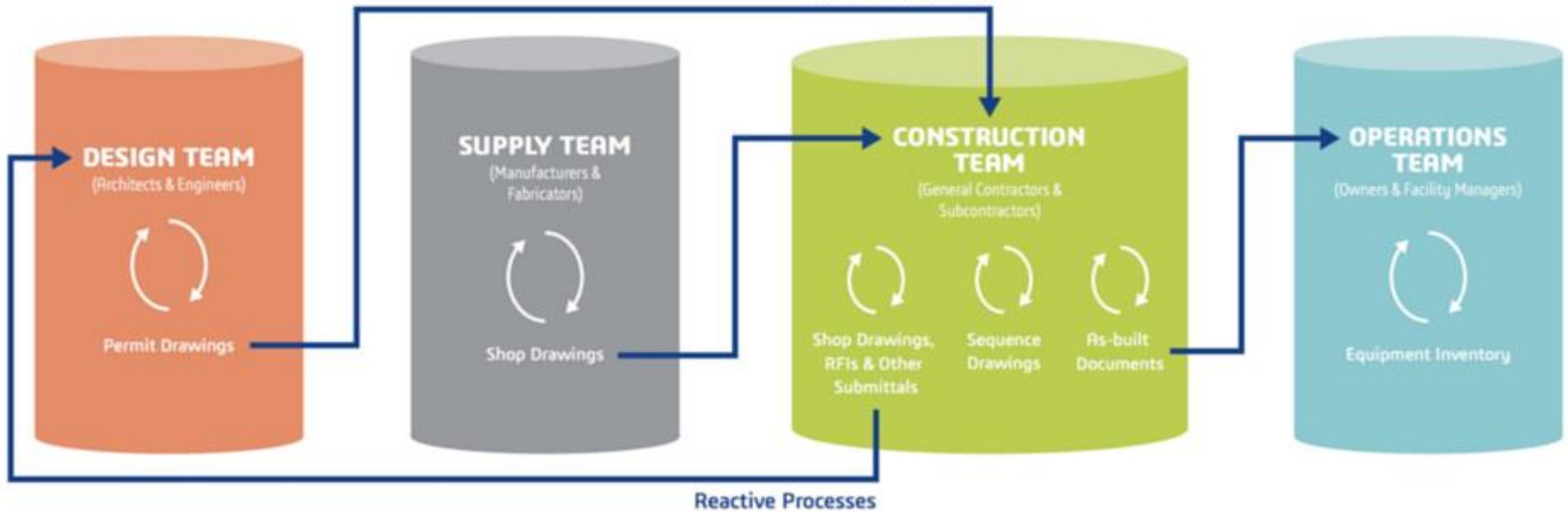

Alternate Procurement Option: Trade Partner/Master Builder Approach



Procurement Strategy is Key to Success

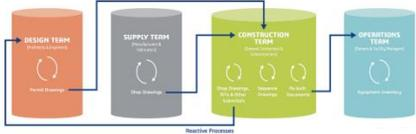

5% Savings

Neutrality

10% Premium

Material Fabrication Planning



Understand the Supply Chain



Photo: Swinerton

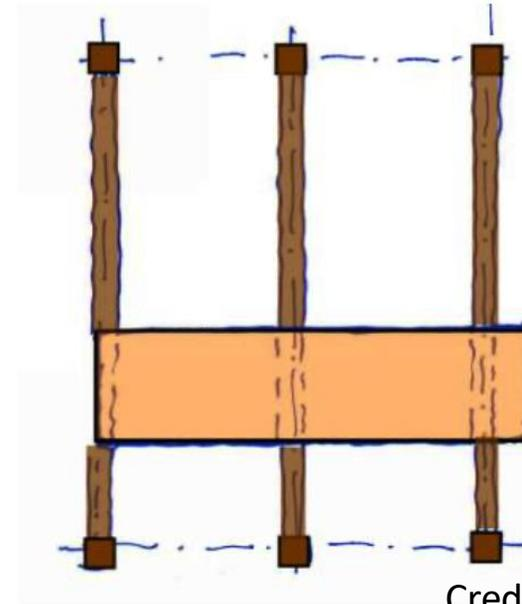
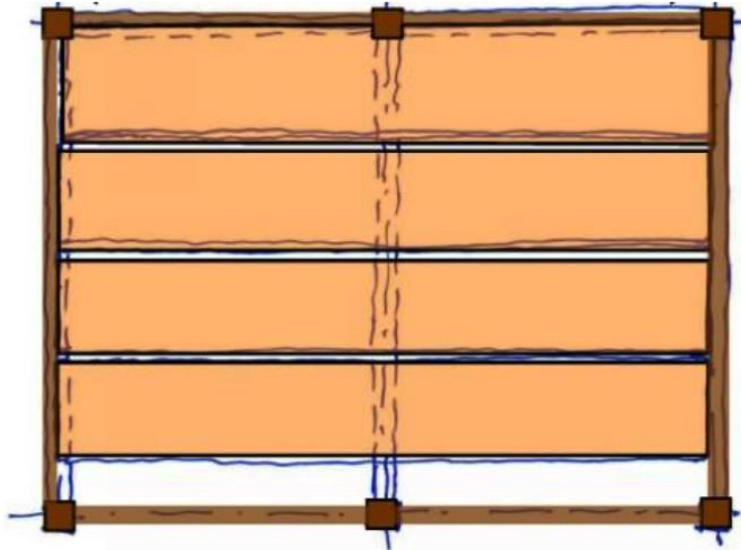
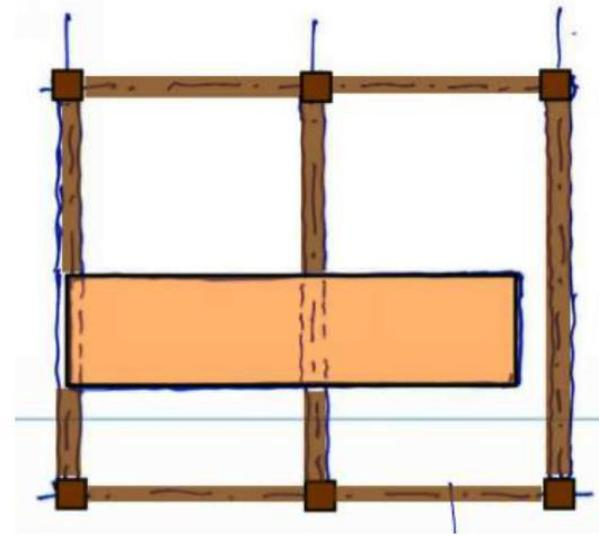
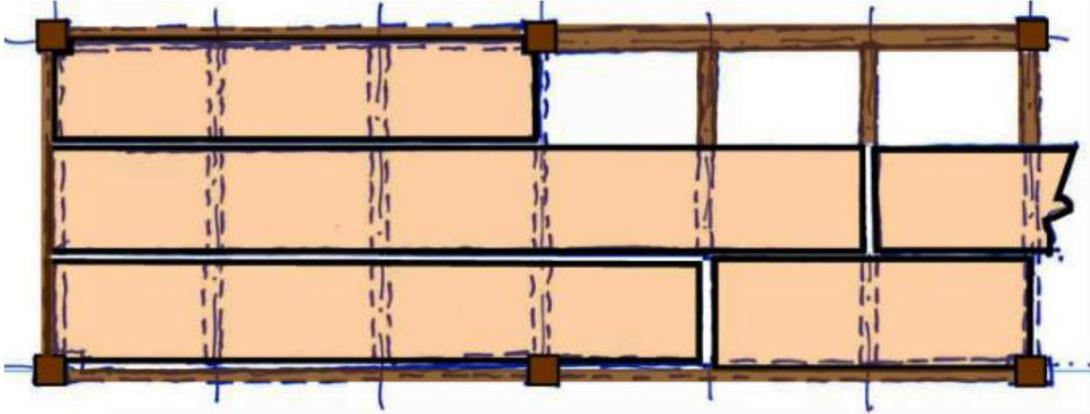

Credit: Tanya Luthi, Entuitive

Understand Manufacturer's Capabilities

Understand Manufacturer's Capabilities

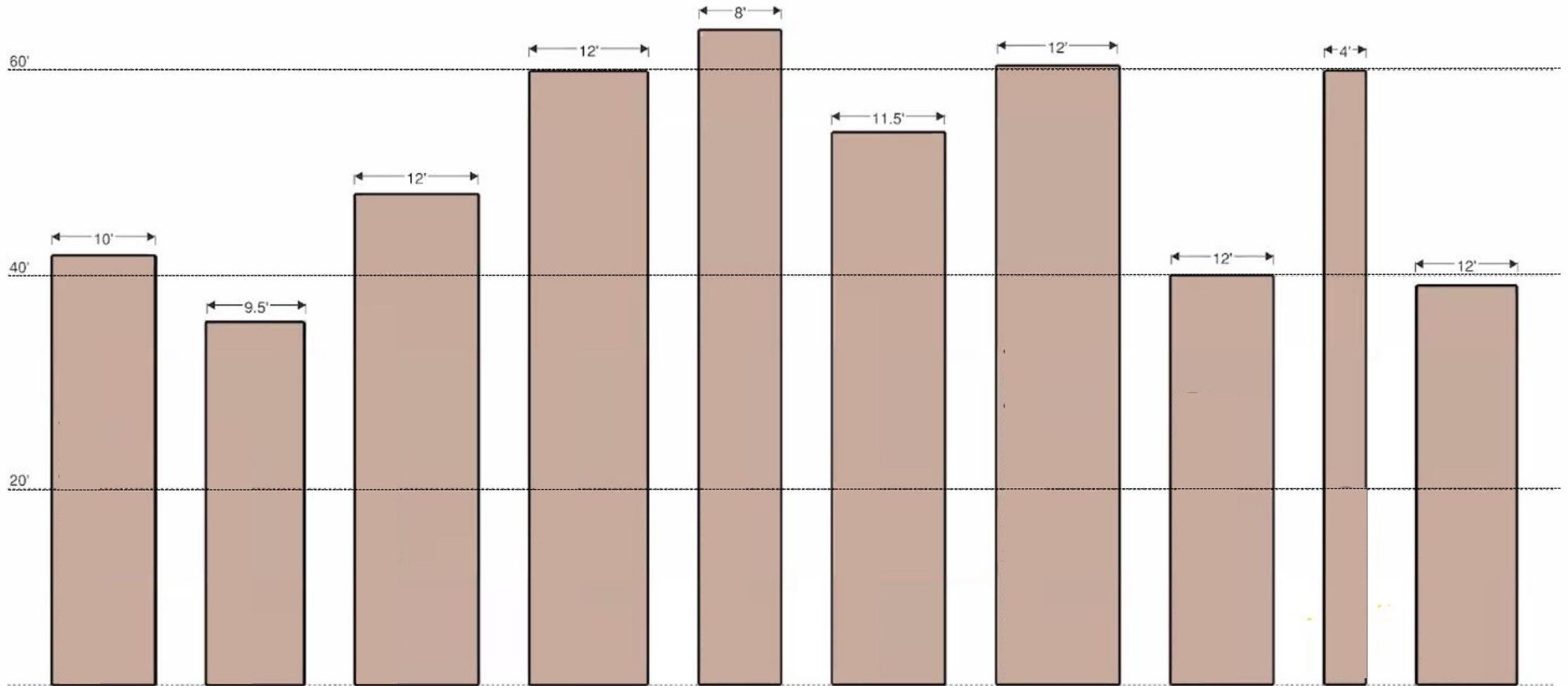

Credit: TimberLab



Embrace the
Prefab Advantage

Tolerances: Interface with Other Structural Materials

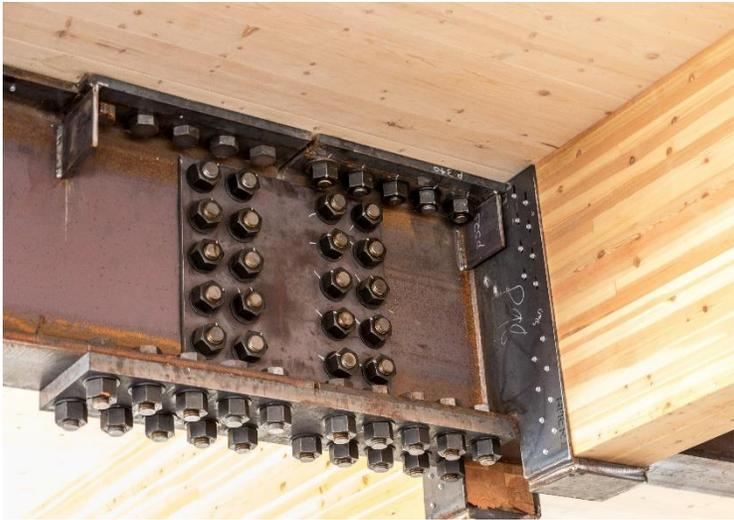

Photos: Swinerton

Schedule Drivers



Procurement Approach Determines Schedule

Compressing the Typical Construction Schedule with Mass Timber ^{13, 15, 16}

Look for these potential schedule savings in comparison to steel and concrete

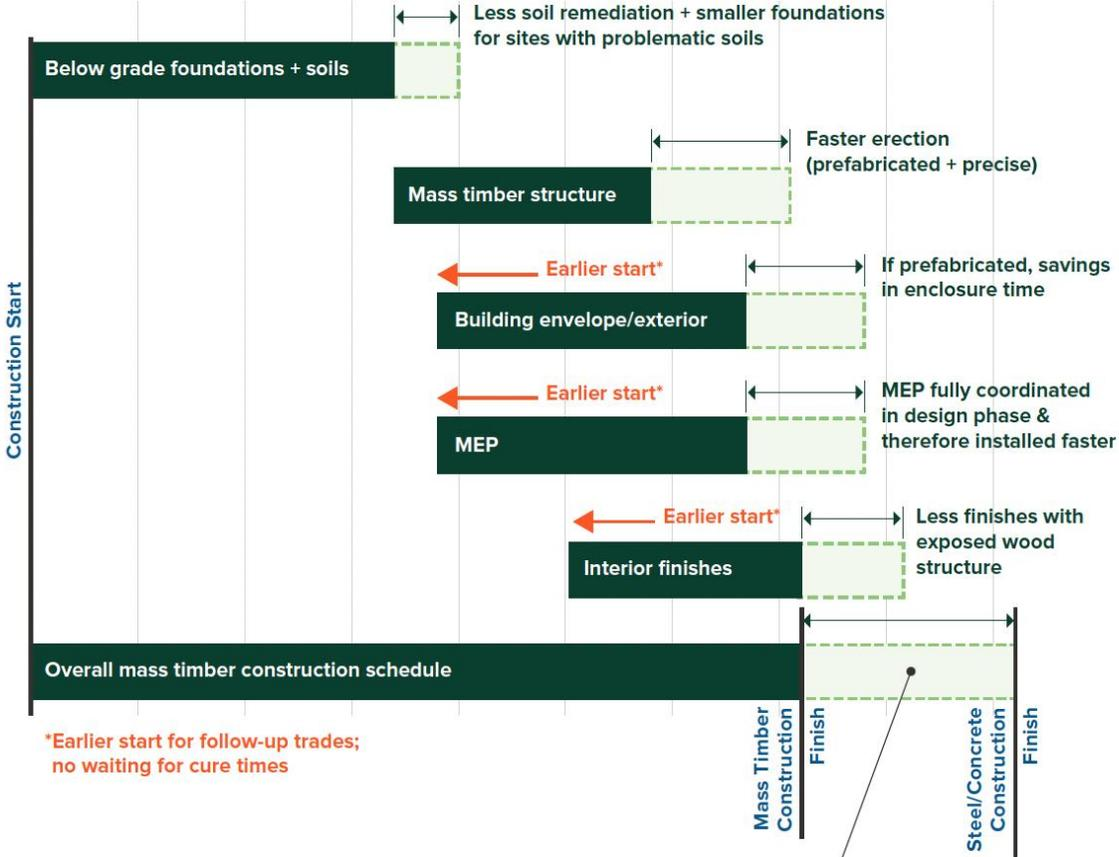

Up to 25% schedule savings
 = Less carrying costs
 + Less GC overhead
 + Ability to lease/occupy sooner

Procurement Logic for Scheduling

Shop drawings, Planning, Fabrication, Delivery

Mass
Timber
Installation

Nov Dec Jan Feb Mar Apr May Jun Jul Aug Sep

Source: Swinerton

Example 6 Story Type IIIA Project

Schedule Comparison

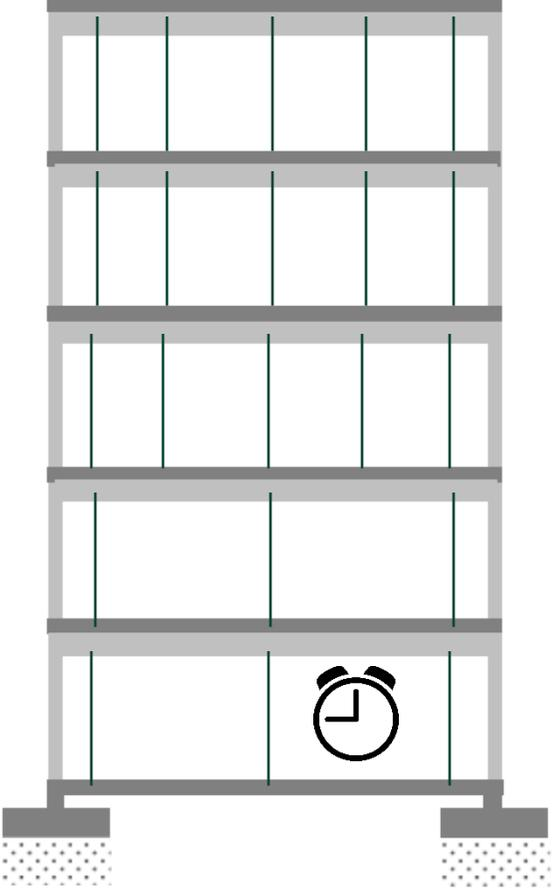
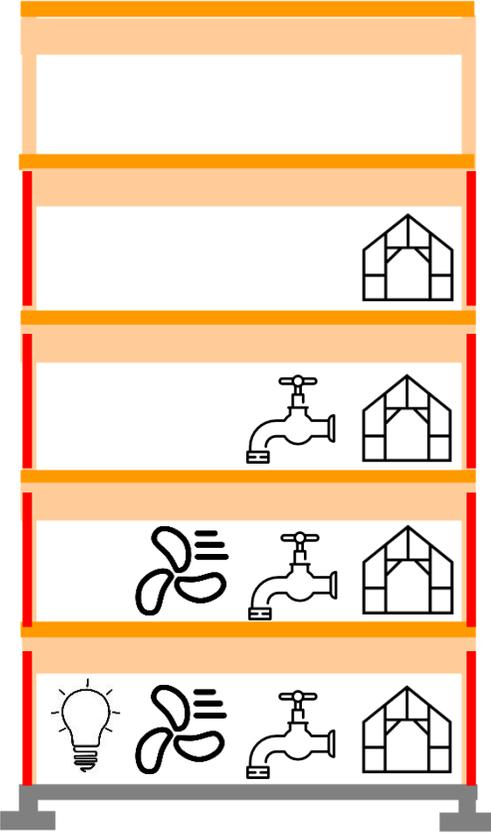
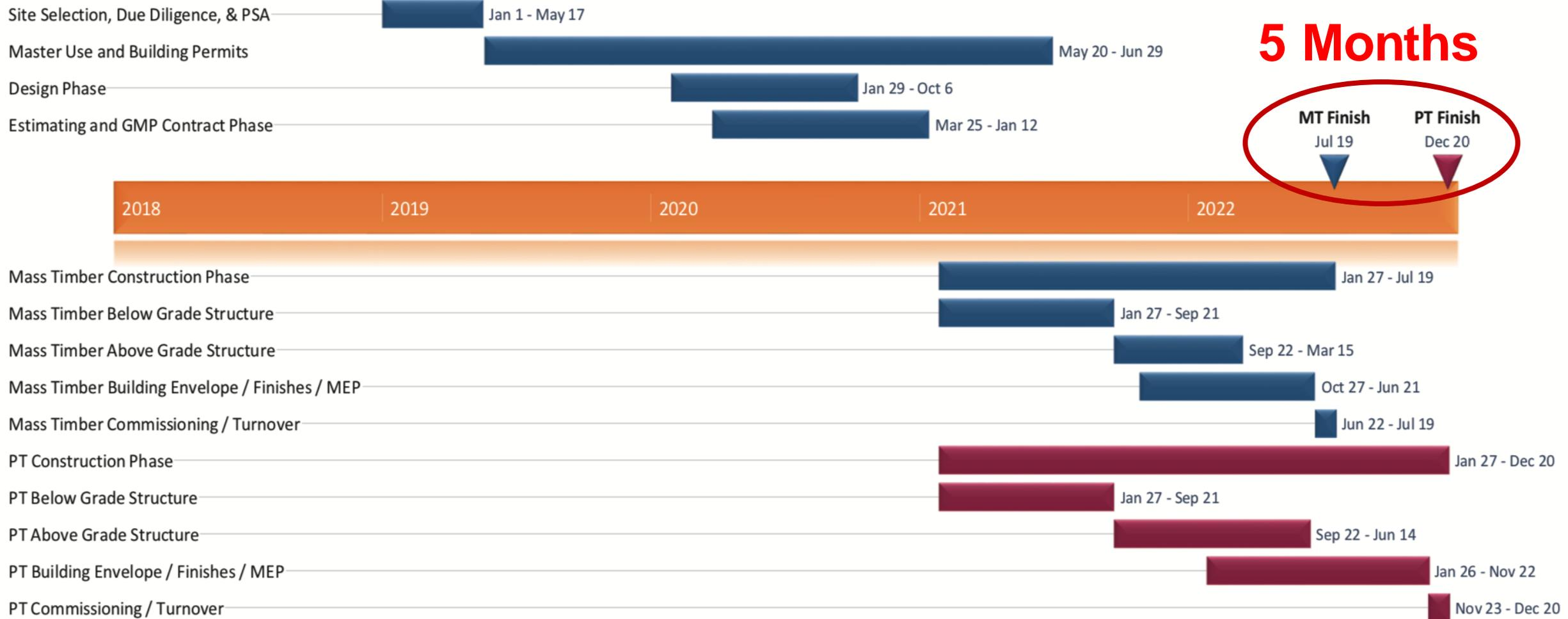

Photo: WoodWorks

Image: Swinerton

Overall Project Schedule Analysis: 12 Story Type IV-B



Schedule Drivers



Schedule Impacts: Hybrid Structures



Schedule Impact on Cost | Value of Time

A large scale MT project can be up to 2% higher in direct costs, but a minimum of 20% lower in project overhead costs. The net result is cost-neutrality and higher value.

BIM/Digital Twins

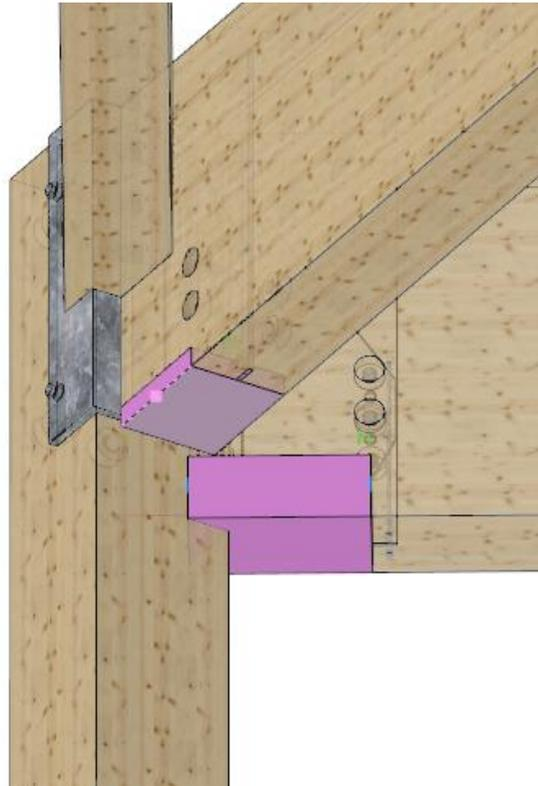
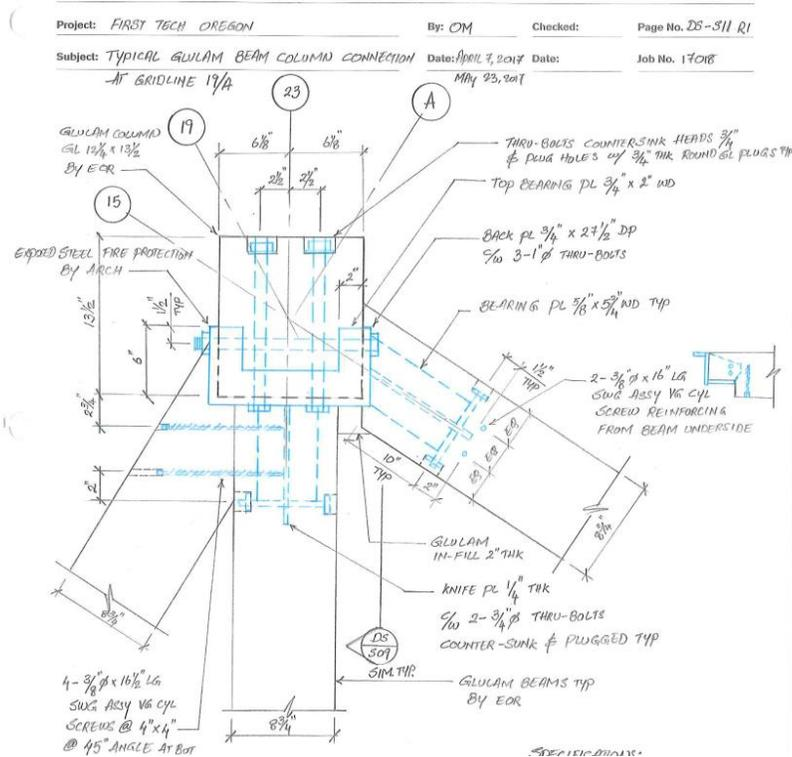

Photos: Swinerton

Embracing BIM for Fabrication

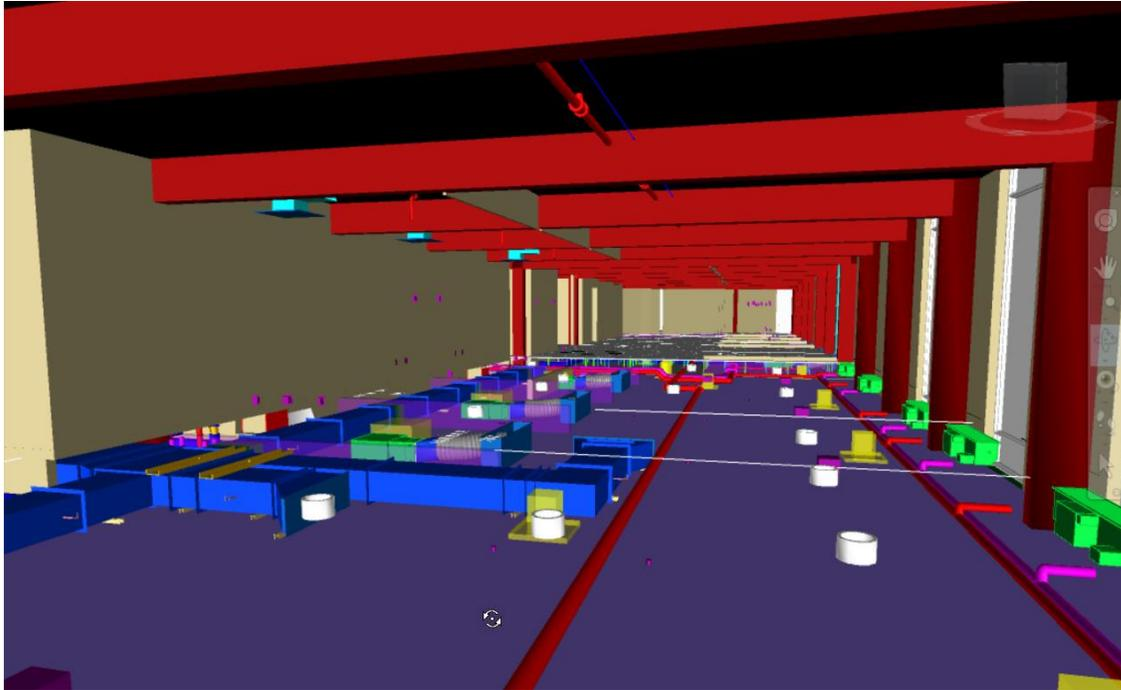

Photos: Swinerton

Early Move-In for Rough-In Trades.



Photos: Swinerton



SITE PLANNING



MATERIAL DELIVERY



Photo: Swinerton



Photo: Swinerton

STAGING

QA/QC



Photo: Swinerton

PICK PLAN



Photo: Swinerton

SITE INSPECTIONS



Tall Mass Timber Special Inspections

**TABLE 1705.5.3
REQUIRED SPECIAL INSPECTIONS OF MASS TIMBER CONSTRUCTION**

<u>Type</u>	<u>Continuous Special Inspection</u>	<u>Periodic Special Inspection</u>
<u>1. Inspection of anchorage and connections of mass timber construction to timber deep foundation systems.</u>		X
<u>2. Inspect erection of mass timber construction</u>		X
<u>3. Inspection of connections where installation methods are required to meet design loads</u>		
<u>3.1. Threaded fasteners</u>		
<u>3.1.1. Verify use of proper installation equipment.</u>		X
<u>3.1.2. Verify use of pre-drilled holes where required.</u>		X
<u>3.1.3. Inspect screws, including diameter, length, head type, spacing, installation angle, and depth.</u>		X
<u>3.2. Adhesive anchors installed in horizontal or upwardly inclined orientation to resist sustained tension loads</u>	X	
<u>3.3. Adhesive anchors not defined in 3.2.</u>		X
<u>3.4. Bolted connections</u>		X
<u>3.5. Concealed connections</u>		X

Planning for Environmental Exposures



- Plan Early
- Risk Evaluation
- Develop Construction Phase Plan
- Execute the Design and Moisture Management Plan
- Monitor

RDH Moisture
Management Guide 1st Ed



Photo: Swinerton



Material Environmental Exposure and Moisture Management

Enroute
Onsite
Post-Install
Other Material

Photo: Alex Schreyer

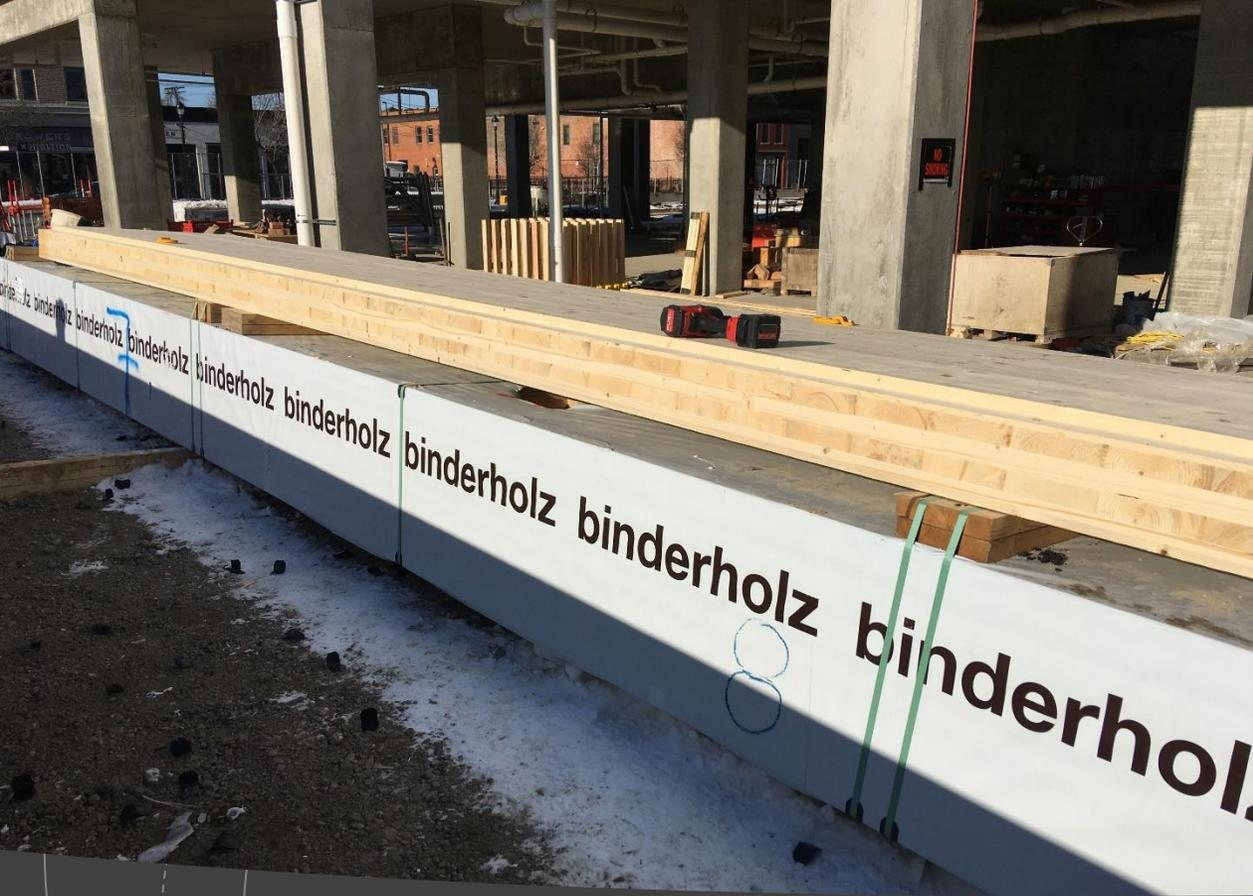

Enroute Exposure

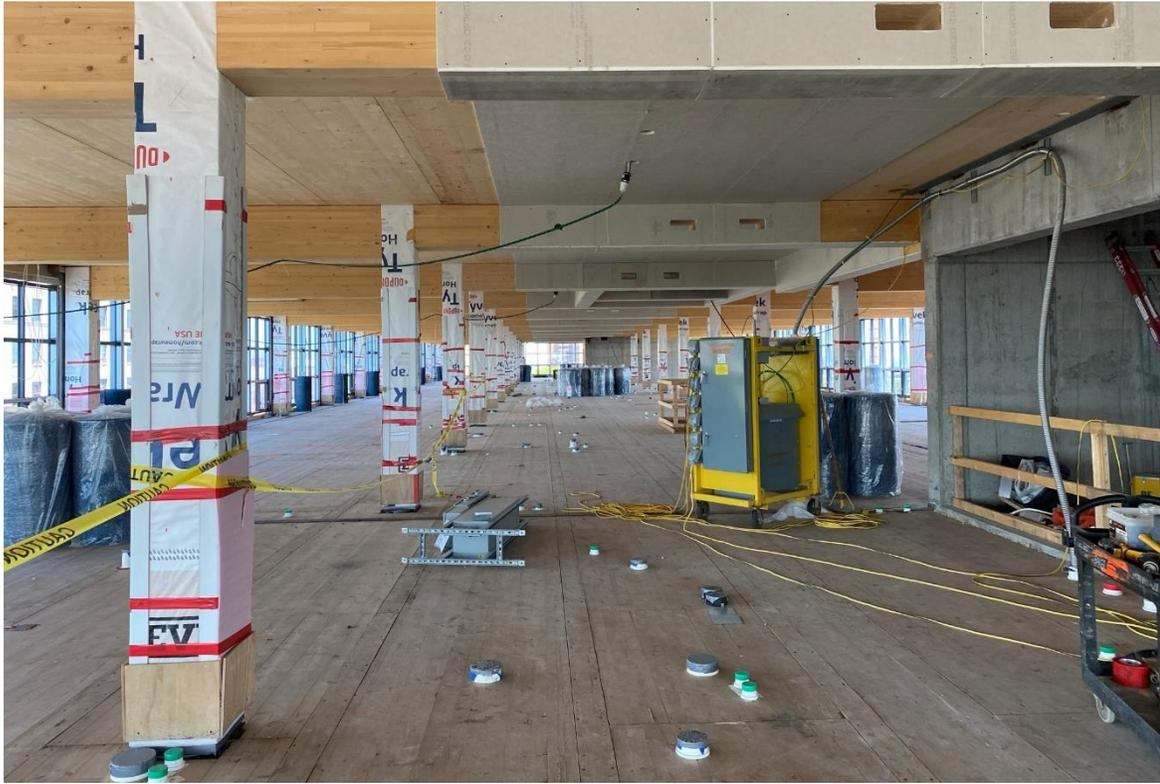

On Site Considerations



On Site Considerations



Onsite Considerations



Other Materials



Workforce Development

Training is the key to efficiency
Training takes time and money

Training versus Education

Resources available to all

- MT Construction Manual
- Installer Curriculum
- Other WW Resources
- CM Workshops
- Previous recorded versions
- Learning Management System

Mass Timber Construction Management Program



MASS TIMBER CONSTRUCTION
MANUAL



8- & 16-HOUR INSTALLER
TRAINING PACKAGE AND
TRAINING CENTERS



COMMUNITY COLLEGE
AND UNIVERSITY CM
PROGRAMS



VIRTUAL AND/OR IN-PERSON
WORKSHOPS



PARTNERSHIPS WITH
CONSTRUCTION ASSOCIATIONS



PROJECT TOURS



ENGAGE WITH GENERAL
CONTRACTORS ACROSS THE US

Partner Training Centers

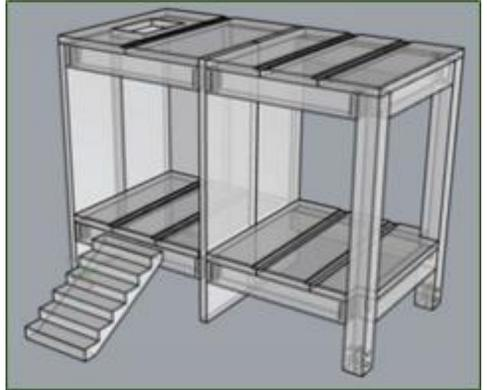
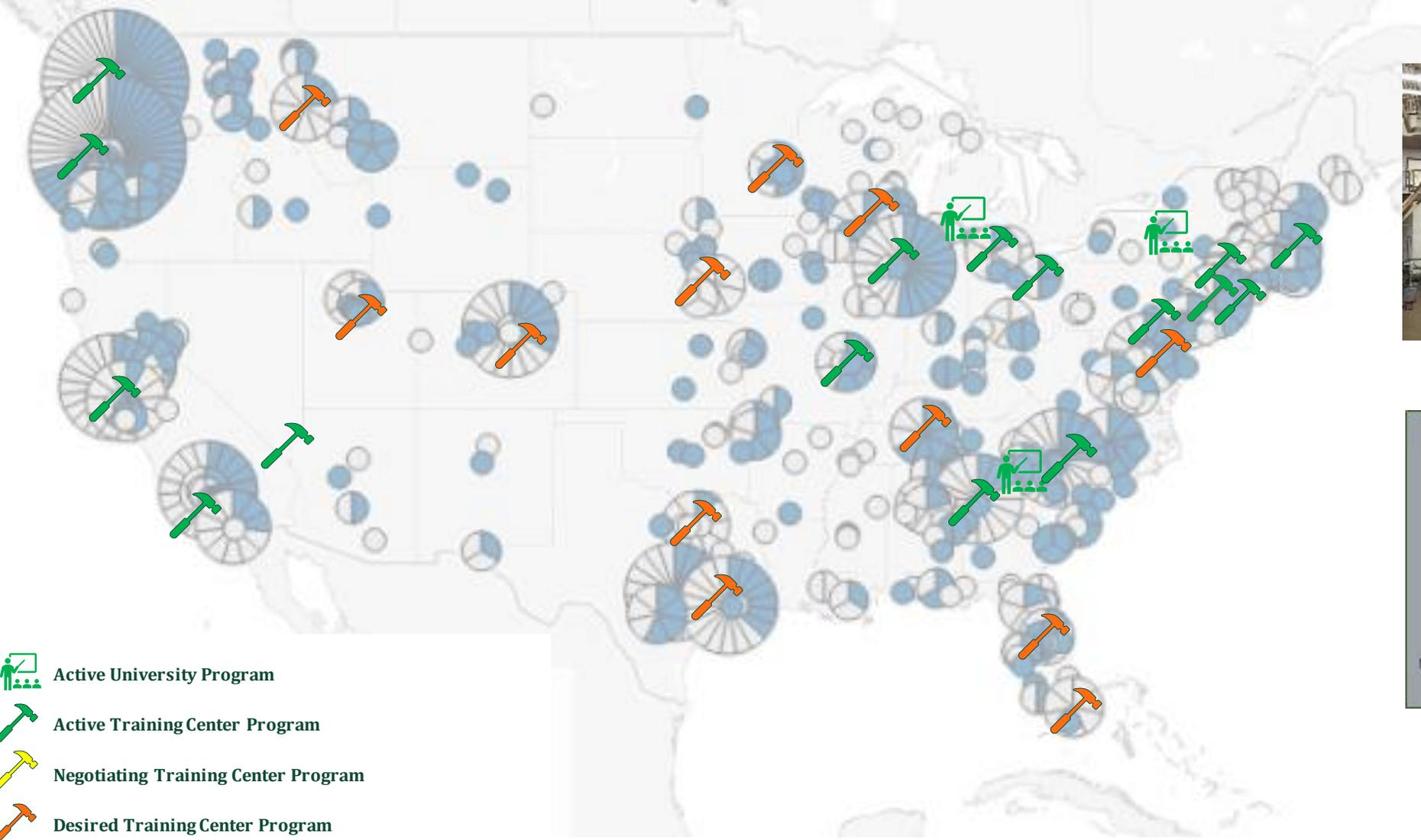



U.S.
Mass Timber
Construction
Manual



Available with any
of the other
resources you've
seen today at
woodworks.org





Designing a wood building? Ask us anything.

FREE PROJECT SUPPORT / EDUCATION / RESOURCES

Nationwide support for the code-compliant design, engineering and construction of non-residential and multi-family wood buildings.

- Allowable Heights/Areas
- Construction Types
- Structural Detailing
- Wood-Framed & Hybrid Systems
- Fire/Acoustic Assemblies
- Lateral System Design
- Alternate Means of Compliance
- Energy-Efficient Detailing
- Building Systems & Technologies

woodworks.org/project-assistance | help@woodworks.org



John W. Olver Design Building at UMass Amherst
Leers Weinzapfel Associates, Equilibrium Consulting
photo © Albert Vecerka / Esto

Questions? Ask me anything.



John O'Donald II, PE
Regional Director
VA, DC, DE, MD, WV
(814) 880-5636
john.odonald@woodworks.org



Brandon Brooks, MBA, PMP
Construction Management Program
Manager
(760) 271-3722
brandon.brooks@woodworks.org



Copyright Materials

This presentation is protected by US
and International Copyright laws.

Reproduction, distribution, display and use of
the presentation without written permission
of the speaker is prohibited.

© The Wood Products Council 2022

Funding provided in part by the Softwood Lumber Board

Disclaimer: The information in this presentation, including, without limitation, references to information contained in other publications or made available by other sources (collectively “information”) should not be used or relied upon for any application without competent professional examination and verification of its accuracy, suitability, code compliance and applicability by a licensed engineer, architect or other professional. Neither the Wood Products Council nor its employees, consultants, nor any other individuals or entities who contributed to the information make any warranty, representative or guarantee, expressed or implied, that the information is suitable for any general or particular use, that it is compliant with applicable law, codes or ordinances, or that it is free from infringement of any patent(s), nor do they assume any legal liability or responsibility for the use, application of and/or reference to the information. Anyone making use of the information in any manner assumes all liability arising from such use.