



Red-I™ Joists



Including Red-I45™, Red-I65™, Red-I90™, Red-I90H™, and Red-I90HS™ Joists

- Lightweight for Fast Installation
- Resists Bowing, Twisting, and Shrinking
- Available in Long Lengths
- FSC Chain-of-Custody Now Available
- Compatible with Standard Framing
- Works with Multiple Spans
- [Limited Product Warranty](#)

RedSPEC™
Product Sizing Software

Download your free copy at RedBuilt.com.

Specify Red-I™ Joists for your next project using RedSpec™ single-member sizing software.



Welcome to RedBuilt

RedBuilt is an exciting business offering building solutions for a broad range of commercial and custom residential applications. In addition to pioneering unique manufacturing technologies, RedBuilt provides world-class service and technical support for architects, specifiers and builders.

RedBuilt gives you access to reliable, innovative products, including RedBuilt™ open web trusses, Red-I™ joists, and RedLam™ LVL beams and headers. And we keep things simple: You'll work with just one service-oriented supplier to get all these products—plus the support you need to build smarter.

RedBuilt: A family of brand-name building products... a source for innovative ideas and solutions... a supplier that's simpler to do business with.

The RedBuilt™ Red-I™ Joist Advantage

Red-I™ joists are lightweight joists suitable for use in roofs and floors in custom residential, multifamily, institutional, and commercial applications. This product is available in multiple series so you can design the most cost-effective system. Other Red-I™ joist benefits include:

- **Dependable Delivery**—RedBuilt plants are located in key market areas, enabling us to deliver materials quickly. Each plant is staffed with experienced personnel who can help solve problems and talk with you about any special project requirements.
- **Minimum Waste**—Red-I™ joists are manufactured to resist twisting and shrinking, and they can be cut to size at the factory so there's virtually no time or material waste prior to installation.
- **Compatibility**—All Red-I™ joists fit into wood frame, masonry, or steel construction, and they can accommodate a wide variety of decking and ceiling materials—including wood, plywood, steel, and gypsum.
- **Easy Mechanical Access**—Knockout holes for ventilation and flexible conduit are provided in the web of the Red-I™ joists. The web can also be cut or drilled to accommodate larger ductwork (see page 19), so costly suspended ceilings can often be eliminated.

TABLE OF CONTENTS

Introduction	2
Features and Benefits	3
Design Center Services	4
Red-I™ Joist Descriptions	4
Design Properties	5
Load Tables	6–9
8' On-Center Roof Span Table	9
Floor Details	10–12
Cantilevers and Outriggers	12–13
Roof Details	14
Rim Board	15
Red-I™ Blocking Panels	15
Web Stiffeners	16
Nailing Information	16
Wind or Seismic Connections	17
Fire and Sound	18
Allowable Holes	19
Deflection Criteria	20
Snowdrift Loading	20
Technical Support and Analysis	21
Q&A	22–23
Red-I™ Joist Specifications	24
Material Weights	25
RedSpec™ Sizing Software	26
Product Warranty	28

ABOUT THIS GUIDE

The RedBuilt™ Red-I45™, I65™, I90™, I90H™, and I90HS™ Joist Specifier's Guide is one of several guides that offer technical information and design recommendations for RedBuilt™ products. This guide provides architects, designers, and engineers with information regarding Red-I™ joists for commercial and custom residential applications.

Product Selection

This guide provides specifiers with technical information about the RedBuilt™ Red-I™ joist product line. However, complex or custom applications can often make specifying the the right products in the right places a challenge — especially when you have factors such as span, wind, load-carrying capacity and other design constraints to consider. But whatever your project entails, RedBuilt is here to help. [Your local RedBuilt technical representative](#), along with our Design Center team, can assist you in choosing the best products and designing the best system for your specific application.

Contact us for help with any of the following:

- Product selection
- Building department calculations
- Complete cost analysis
- System selection (system packages can include horizontal framing, load-carrying beams, headers, wall framing, mansard framing, and accessories)

Products for Every Application

In addition to Red-I™ joists, RedBuilt™ offers a variety of other engineered lumber products that are ideal for use in commercial and custom residential projects. For more information, contact your RedBuilt technical representative or visit www.RedBuilt.com to download literature for products such as [tapered Red-I™ joists](#), [open-web trusses](#), and [RedLam™ LVL](#).

Unsurpassed Technical Support

RedBuilt has one of the largest networks of technical representatives in the business. Their services include consultation, computer-assisted design and layout, delivery coordination, and installation review. They can suggest cost-reduction techniques and check special application requirements. In addition, they're backed by a staff of professional engineers who provide comprehensive technical support when needed. Special requests are accommodated wherever practical, and they offer cost analysis, engineering analysis, assistance with building code approvals—even the creation of special product applications for more creative designs. The goal of RedBuilt technical support is to help architects and engineers achieve quality design applications with the most cost-efficient product selection possible.



Our [network of technical representatives](#) offers a wide range of services to help guide your projects through planning and construction.

Resource Efficiency

Consider all the positive attributes of wood when selecting your building material of choice. In addition to its structural properties, high strength-to-weight ratio, and ease of construction, wood is a naturally occurring, renewable resource that requires less energy to produce than steel or concrete. And it sequesters carbon — whether on the stump or in your structure.

Our Red-I™ joists, as well as other RedBuilt™ products, are now available with FSC credits. Whether you're looking for LEED certification or simply want to ensure efficient use of raw materials, we can help. By making better use of every tree, RedBuilt produces cost-effective, consistently available engineered wood products that reduce environmental impact. The result is a quality wood product that offers superior strength and reliable performance.



The mark of
responsible forest
management

DESIGN CENTER SERVICES

Upon request, RedBuilt can provide the following services for the products described in this Red-I™ Joist Specifier's Guide:

- A complete design package including layout drawings (placement diagrams) and detailed design calculations.
- Review and analysis of the application.
- Drawings and/or calculations sealed by a professional engineer.



Our technical support team offers professional capabilities in the design and application of all RedBuilt™ products.

Installation Review

Although responsibility for proper installation lies with the contractor-builder, RedBuilt provides detailed suggestions and guidelines for installation. If requested, a RedBuilt representative will visit the site to verify the contractor's understanding of proper installation. RedBuilt professional engineers also are available to help solve jobsite application problems.

Engineering Responsibility Position Statement

RedBuilt is a manufacturer of proprietary structural components.

It employs a staff of professional engineers to aid in the development, manufacture, and marketing of its products. RedBuilt does not replace or accept the responsibility of the design professional of record for any structure.

RedBuilt accepts the delegation of engineering responsibility only for the products it manufactures, provided that the application conditions are specified by the design professional of record, or other responsible party when a design professional is not engaged. RedBuilt provides engineering in the design of its products and does not displace the need on any project for a design professional of record.

RED-I™ JOIST DESCRIPTIONS

This guide covers five series of joists: Red-I45™ Red-I65™ Red-I90™ Red-I90H™ and Red-I90HS™. These joists are primarily intended for commercial applications such as retail stores, office buildings, schools, restaurants, multi-family, hotels, warehouses, and nursing homes. They are typically designed, manufactured, and sold by RedBuilt for each specific job. Contact your RedBuilt representative for more information.

Some series of Red-I™ joists are available with tapered profiles for use in certain roof applications. [Contact your RedBuilt representative](#) for determining availability and for application assistance.

Red-I™ joists are normally produced without camber. However, camber is available at 2,250' radius as a special order for I45™ I65™ I90™ and I90H™ series joists. Camber is not recommended for floors, or for multiple-span or cantilever applications.

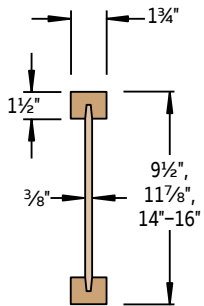

Red-I45™

Top and bottom flanges of 1 1/2" x 1 3/4" RedLam™ LVL with 3/8" OSB web.

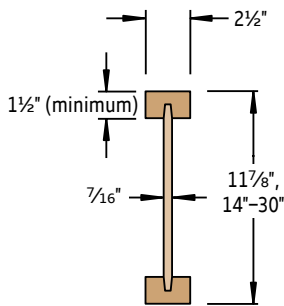

Red-I65™

Top and bottom flanges of 1 1/2" (minimum) x 2 1/2" RedLam™ LVL with 7/16" OSB web.

- Also available in a tapered profile (Red-I65T™). Check with your technical representative for availability.

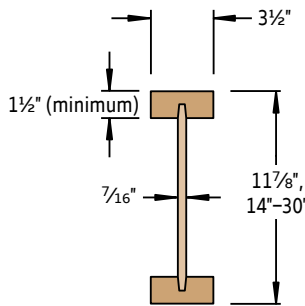

Red-I90™

Top and bottom flanges of 1 1/2" (minimum) x 3 1/2" RedLam™ LVL with 7/16" OSB web.

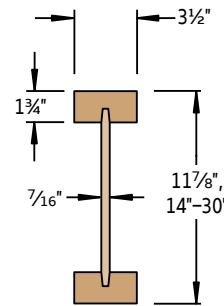

Red-I90H™

Top and bottom flanges of 1 3/4" x 3 1/2" RedLam™ LVL with 7/16" OSB web.

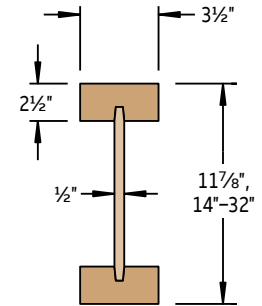

Red-I90HS™

Top and bottom flanges of 2 1/2" x 3 1/2" RedLam™ LVL with 1/2" OSB web.

- For heavy loads and 8' on-center roof systems
- Provides increased bending strength and stiffness.

Joist depths from 14" to 32" are available in 2" increments.

DESIGN PROPERTIES

Joist Depth	Joist Weight (lbs/ft)	Reference Design Values												
		Moment ⁽¹⁾ M _r (ft.-lbs)	Shear ⁽²⁾ V _r (lbs)	EI x 10 ⁶ (in. ² -lbs)	EI ⁽³⁾ x 10 ⁶ Red-I™ Joist with Nailed Floor Sheathing (in. ² -lbs)	EI ⁽³⁾ x 10 ⁶ Red-I™ Joist with Glue-Nailed Floor Sheathing (in. ² -lbs)	End Reaction (lbs) ⁽⁴⁾⁽⁵⁾				Intermediate Reaction (lbs) ⁽⁴⁾⁽⁵⁾			
							1 3/4" ⁽⁶⁾ Bearing		3 1/2" Bearing		3 1/2" Bearing		5 1/4" Bearing	
							Web Stiffeners ⁽⁷⁾		Web Stiffeners ⁽⁷⁾		Web Stiffeners ⁽⁷⁾		Web Stiffeners ⁽⁷⁾	
No	Yes	No	Yes	No	Yes	No	Yes	No	Yes					
Red-I45™ Joist														
9 1/2"	2.2	3,620	1,590	185	221	250	1,015	NA	1,560	NA	2,025	NA	2,575	NA
11 1/8"	2.5	4,685	1,785	319	375	420	1,015	1,225	1,560	1,785	2,025	2,385	2,575	2,930
14"	2.8	5,570	1,960	474	553	615	1,015	1,225	1,560	1,915	2,025	2,385	2,575	2,930
16"	3.0	6,390	2,120	653	756	839	1,015	1,225	1,560	1,915	2,025	2,385	2,575	2,930
Red-I65™ Joist														
11 1/8"	3.6	6,750	2,255	450	512	561	1,375	1,745	1,885	2,255	2,745	3,120	3,365	3,735
14"	3.9	8,030	2,540	666	752	821	1,375	1,750	1,885	2,505	2,745	3,365	3,365	3,985
16"	4.2	9,210	2,810	913	1,025	1,116	1,375	1,750	1,885	2,625	2,745	3,490	3,365	4,105
18"	4.4	10,380	3,080	1,205	1,348	1,462	1,375	1,750	1,885	2,750	2,745	3,615	3,365	4,230
20"	4.7	11,540	3,345	1,545	1,722	1,864	NA	1,750	NA	2,875	NA	3,740	NA	4,355
22"	5.0	12,690	3,615	1,934	2,149	2,322	NA	1,750	NA	3,000	NA	3,860	NA	4,480
24"	5.3	13,830	3,200	2,374	2,632	2,838	NA	1,750	NA	3,125	NA	3,875	NA	4,605
26"	5.5	14,960	3,200	2,868	3,172	3,416	NA	1,750	NA	3,200	NA	4,725 ⁽⁸⁾	NA	5,345 ⁽⁹⁾
28"	5.8	16,085	3,200	3,417	3,772	4,056	NA	1,750	NA	3,200	NA	4,850 ⁽⁸⁾	NA	5,470 ⁽⁹⁾
30"	6.1	17,205	3,200	4,025	4,434	4,762	NA	1,750	NA	3,200	NA	4,975 ⁽⁸⁾	NA	5,590 ⁽⁹⁾
Red-I90™ Joist														
11 1/8"	4.6	9,605	2,255	621	687	741	1,400	1,715	1,885	2,200	3,350	3,665	3,965	4,285
14"	4.9	11,430	2,540	913	1,005	1,079	1,400	1,875	1,885	2,355	3,350	3,825	3,965	4,440
16"	5.2	13,115	2,810	1,246	1,366	1,462	1,400	2,030	1,885	2,515	3,350	3,980	3,965	4,600
18"	5.4	14,785	3,080	1,635	1,786	1,908	1,400	2,030	1,885	2,515	3,350	3,980	3,965	4,600
20"	5.7	16,435	3,345	2,085	2,272	2,422	NA	2,190	NA	2,675	NA	4,140	NA	4,755
22"	6.0	18,075	3,615	2,597	2,824	3,006	NA	2,345	NA	2,830	NA	5,090	NA	5,705
24"	6.3	19,700	3,400	3,172	3,442	3,659	NA	2,345	NA	2,830	NA	5,405	NA	6,020
26"	6.5	21,315	3,400	3,814	4,132	4,387	NA	2,450	NA	2,990	NA	6,180 ⁽⁸⁾	NA	6,795 ⁽⁹⁾
28"	6.8	22,915	3,400	4,525	4,895	5,191	NA	2,450	NA	3,145	NA	6,335 ⁽⁸⁾	NA	6,800 ⁽⁹⁾
30"	7.1	24,510	3,400	5,306	5,732	6,073	NA	2,450	NA	3,145	NA	6,655 ⁽⁸⁾	NA	6,800 ⁽⁹⁾
Red-I90H™ Joist														
11 1/8"	4.6	10,960	2,300	687	755	810	1,400	1,715	1,885	2,200	3,495	3,810	4,100	4,420
14"	4.9	13,090	2,600	1,015	1,109	1,185	1,400	1,875	1,885	2,355	3,495	3,970	4,100	4,575
16"	5.2	15,065	2,880	1,389	1,512	1,610	1,400	2,030	1,885	2,515	3,495	4,130	4,100	4,735
18"	5.4	17,010	3,160	1,827	1,982	2,106	1,400	2,030	1,885	2,515	3,495	4,130	4,100	4,735
20"	5.7	18,945	3,445	2,331	2,522	2,676	NA	2,190	NA	2,675	NA	4,285	NA	4,890
22"	6.0	20,855	3,725	2,904	3,136	3,321	NA	2,345	NA	2,830	NA	5,235	NA	5,840
24"	6.3	22,755	3,800	3,549	3,825	4,046	NA	2,345	NA	2,830	NA	5,425	NA	6,155
26"	6.5	24,645	3,800	4,266	4,590	4,850	NA	2,450	NA	2,990	NA	6,315 ⁽⁸⁾	NA	6,920 ⁽⁹⁾
28"	6.8	26,520	3,800	5,059	5,436	5,737	NA	2,450	NA	3,145	NA	6,470 ⁽⁸⁾	NA	7,080 ⁽⁹⁾
30"	7.1	28,380	3,800	5,930	6,363	6,710	NA	2,450	NA	3,145	NA	6,790 ⁽⁸⁾	NA	7,395 ⁽⁹⁾
Red-I90HS™ Joist														
11 1/8"	6.0	16,050	2,320	900	974	1,034	1,835	2,320	2,150	2,320	3,995	4,650	4,690	5,345
14"	6.3	19,425	2,565	1,355	1,457	1,538	1,835	2,565	2,150	2,565	3,995	4,980	4,690	5,670
16"	6.6	22,550	2,790	1,876	2,008	2,113	1,835	2,790	2,150	2,790	3,995	4,980	4,690	5,670
18"	7.0	25,640	3,020	2,488	2,654	2,787	1,835	3,020	2,150	3,020	3,995	5,310	4,690	6,000
20"	7.3	28,695	3,250	3,195	3,399	3,562	NA	3,250	NA	3,250	NA	5,425	NA	6,330
22"	7.6	31,725	3,480	3,998	4,244	4,442	NA	3,475	NA	3,480	NA	5,425	NA	6,330
24"	7.9	34,730	3,710	4,901	5,194	5,428	NA	3,500	NA	3,710	NA	5,425	NA	6,655
26"	8.2	37,715	3,940	5,905	6,249	6,523	NA	3,500	NA	3,940	NA	6,985 ⁽⁸⁾	NA	7,675 ⁽⁹⁾
28"	8.5	40,680	4,165	7,014	7,412	7,730	NA	3,500	NA	4,165	NA	6,985 ⁽⁸⁾	NA	7,675 ⁽⁹⁾
30"	8.8	43,630	4,375	8,230	8,687	9,052	NA	3,500	NA	4,375	NA	7,310 ⁽⁸⁾	NA	8,005 ⁽⁹⁾
32"	9.1	46,560	4,375	9,555	10,075	10,490	NA	3,500	NA	4,375	NA	7,640 ⁽⁸⁾	NA	8,335 ⁽⁹⁾

- (1) Do not increase joist resistive moment properties by a repetitive-member-use factor.
 - (2) For possible increases in shear capacity see shear design information at right.
 - (3) For deflection calculation only. Assumes 24" joist spacing with a 24" span-rated panel.
 - (4) Interpolation between bearing lengths is permitted for allowable design reactions.
 - (5) Reaction capacity has been determined based on RedBuilt™ products. Allowable bearing on supporting members shall be checked.
 - (6) For Red-I90HS™, use a bearing length of 2 1/2".
 - (7) Refer to page 16 for web stiffener details.
 - (8) 5 1/4" bearing length is required at intermediate reactions.
 - (9) 7" bearing length is required at intermediate reactions.
- The stated allowable design properties are for loads of normal duration. Adjustments to the allowable design values shall be in accordance with the applicable code.

Red-I™ Joist Shear Design

When joists are used as simple span members, the design shear is equal to the shear at the face of the support.

When joists **up to 24" in depth** are used as multiple-span members, the design shear is the calculated shear at the interior support reduced by the following:

$$R = \frac{W}{V_{12}} \leq 18\%$$

Where: R is the percent reduction
W is the uniform load in plf
V₁₂ is the reference design shear for an 11 1/8" deep joist (lbs.)

LOAD TABLES

Instructions for Load Tables on pages 7–9

To size floor joists:

- Calculate total load and live load in pounds per linear foot (plf).
- Check both total load (100% TL) and live load (100% LL). Live load (100% LL) values may be increased with a glue-nailed floor system; contact your RedBuilt representative for assistance.

To size roof joists:

- Calculate total load in pounds per linear foot (plf).
- Check the appropriate snow load area (115% TL) value or non-snow load area (125% TL) value to determine the maximum allowable total load.

Span	11 7/8"		14"		16"	
	100% TL	115% TL	100% TL	115% TL	100% TL	115% TL
12'	320	368	354	407	388	442
	252	401	350	442	*	^

100% TL (Total Load)
Use this and the 100% LL to select floor member. This is the maximum allowable total load in pounds per linear foot of joist. Values are limited by deflection equal to L/240 at total load.

115% TL (Total Load)
Use this to select roof member in snow load areas. This is the maximum allowable total load in pounds per linear foot of joist. Values are limited by deflection equal to L/180 at total load.

100% LL (Live Load)
Use this and the 100% TL to select floor member. This number is the maximum allowable live load capacity in pounds per linear foot of joist. Value is based on the **Commercial Floor Deflection Limit** shown on page 20.

125% TL (Total Load)
Use this to select roof member in non-snow load areas. This is the maximum allowable total load in pounds per linear foot of joist. Values are limited by deflection equal to L/180 at total load.

Consult local codes to verify deflection limits required for specific applications.

General Notes for Load Tables on pages 7–9

- Values shown are maximum allowable load capacities based on the following assumptions:
 - Simple span; horizontal clear distance between supports.
 - Uniformly loaded conditions with 2 1/2" bearing length. Web stiffeners are assumed for joist depths greater than 9 1/2". Other capacities may be possible with different criteria; contact your RedBuilt representative.
 - Positive drainage in roof applications (3/4" per foot slope minimum).
 - Composite action is not considered for deflection.
 - **Floor Total Load** deflection limit is L/240.
 - **Floor Live Load** deflection limit is based on commercial deflection criteria shown on page 20.
 - **Roof Total Load** deflection limit is L/180.
- Camber (2,250' radius) is available for simple-span applications only (not available for Red-I90HS™). **Contact your RedBuilt representative for availability.**
- For span or loading conditions not covered by these tables (such as multiple spans or concentrated loads), contact your RedBuilt representative for assistance.

Visit www.RedBuilt.com to find your local representative.

Red-I45™ Joist Allowable Uniform Load (PLF)

Span	Depth							
	9½"		11⅞"		14"		16"	
	100% TL	115% TL	100% TL	115% TL	100% TL	115% TL	100% TL	115% TL
100% LL	125% TL	100% LL	125% TL	100% LL	125% TL	100% LL	125% TL	
10'	245	282	288	331	299	344	299	344
	160	307	257	360	*	373	*	373
12'	195	224	240	276	249	287	249	287
	98	244	162	301	230	312	*	312
14'	129	165	186	214	214	246	214	246
	64	173	107	233	154	268	205	268
16'	89	119	143	164	170	196	188	216
	44	119	74	179	106	213	143	235
18'	64	85	107	130	135	155	154	178
	28	85	47	141	69	168	92	193
20'	63	80	105	109	109	126	125	144
	63	30	106	46	46	136	63	157
22'	48	81	81	89	89	104	104	119
	48	81	35	113	48	130		

Table Footnotes

- * Indicates total load (TL) value controls.
- Red numbers refer to 115% total load (TL).

See Load Table Instructions and General Notes on page 6.

Red-I65™ Joist Allowable Uniform Load (PLF)

Span	Depth																				
	11⅞"		14"		16"		18"		20"		22"		24"		26"		28"		30"		
	100% TL	115% TL	100% TL	115% TL	100% TL	115% TL	100% TL	115% TL	100% TL	115% TL	100% TL	115% TL	100% TL	115% TL	100% TL	115% TL	100% TL	115% TL	100% TL	115% TL	
100% LL	125% TL	100% LL	125% TL	100% LL	125% TL	100% LL	125% TL	100% LL	125% TL	100% LL	125% TL	100% LL	125% TL	100% LL	125% TL	100% LL	125% TL	100% LL	125% TL	100% LL	125% TL
10'	386	444	407	469	418	480	428	492	439	504	449	517	460	529	466	536	466	536	466	536	
	347	482	*	509	*	522	*	535	*	548	*	562	*	575	*	583	*	583	*	583	
12'	322	371	340	391	349	401	358	411	366	421	375	432	384	442	389	448	389	448	389	448	
	220	403	310	426	*	436	*	447	*	458	*	469	*	480	*	487	*	487	*	487	
14'	269	309	292	336	300	345	307	353	315	362	322	371	330	379	334	385	334	385	334	385	
	147	336	210	365	277	375	*	384	*	393	*	403	*	412	*	418	*	418	*	418	
16'	206	237	245	282	262	302	269	309	276	317	282	325	289	332	293	337	293	337	293	337	
	102	258	146	307	194	328	249	336	*	345	*	353	*	361	*	366	*	366	*	366	
18'	149	188	194	223	223	256	239	275	245	282	251	289	257	296	261	300	261	300	261	300	
	65	199	94	243	126	279	163	299	204	307	248	314	*	321	*	326	*	326	*	326	
20'	111	148	157	181	181	208	204	234	221	254	226	260	231	266	235	270	235	270	235	270	
	44	148	64	197	86	226	112	255	140	276	172	283	206	289	*	293	*	293	*	293	
22'	85	113	123	150	149	172	168	194	187	216	206	237	211	242	213	246	213	246	213	246	
	34	113	49	163	66	187	86	211	108	234	133	257	161	263	190	267	*	267	*	267	
24'	88	96	126	126	145	142	163	158	181	173	199	189	217	196	225	196	225	196	225		
	88	38	129	52	157	68	177	85	197	105	217	127	236	151	245	177	245	*	245		
26'	70	77	102	104	123	121	139	134	155	148	170	161	185	174	201	181	208	181	208		
	70	30	102	41	134	54	151	68	168	84	185	102	201	122	218	143	226	166	226		
28'	56	83	84	106	104	120	116	133	127	147	139	160	150	173	162	186	168	193			
	56	83	33	112	44	130	55	145	69	159	83	174	100	188	117	202	136	210			
30'	46	68	92	90	104	101	116	111	128	121	139	131	151	141	162	151	173				
	46	68	92	36	114	46	126	57	139	69	151	82	164	97	176	113	189				
32'	38	56	77	75	92	89	102	98	112	106	122	115	133	124	143	133	152				
	38	56	77	30	100	38	111	47	122	57	133	69	144	81	155	95	166				
34'	32	47	64	81	79	90	86	100	94	108	102	117	110	126	117	135					
	32	47	64	84	32	98	40	108	48	118	58	128	68	137	80	147					
36'	40	54	71	81	77	89	84	97	91	105	98	113	105	121							
	40	54	71	88	34	97	41	105	49	114	58	122	68	131							
38'	34	46	61	72	69	80	75	87	82	94	88	101	94	108							
	34	46	61	78	29	87	35	94	42	102	50	110	58	118							
40'	29	40	52	65	68	78	72	85	74	85	79	91	85	98							
	29	40	52	67	78	30	85	36	92	43	99	50	106								

Red-I90HS™ Joist Allowable Uniform Load (PLF)

Span	Depth																					
	11 7/8"		14"		16"		18"		20"		22"		24"		26"		28"		30"		32"	
	100% TL	115% TL	100% TL	115% TL	100% TL	115% TL	100% TL	115% TL	100% TL	115% TL	100% TL	115% TL	100% TL	115% TL	100% TL	115% TL	100% TL	115% TL	100% TL	115% TL	100% TL	115% TL
14'	327	376	362	416	393	452	426	490	458	527	490	564	494	568	494	568	494	568	494	568	494	568
	263	409	*	452	*	492	*	532	*	573	*	613	*	617	*	617	*	617	*	617	*	617
16'	287	330	317	364	345	396	373	429	402	462	429	494	432	497	432	497	432	497	432	497	432	497
	186	358	265	396	*	431	*	467	*	502	*	537	*	541	*	541	*	541	*	541	*	541
18'	255	293	282	324	307	353	332	382	357	411	382	439	385	443	385	443	385	443	385	443	385	443
	121	319	175	352	232	383	295	415	*	447	*	478	*	481	*	481	*	481	*	481	*	481
20'	209	264	254	292	276	318	299	344	322	370	344	396	347	399	347	399	347	399	347	399	347	399
	83	278	121	317	161	345	207	374	256	402	310	430	*	433	*	433	*	433	*	433	*	433
22'	161	215	231	266	251	289	272	313	293	337	313	360	315	363	315	363	315	363	315	363	315	363
	64	215	94	289	126	314	162	340	202	366	245	391	292	394	*	394	*	394	*	394	*	394
24'	127	169	185	244	230	265	249	287	268	309	287	330	289	333	289	333	289	333	289	333	289	333
	50	169	74	247	100	288	129	312	161	336	197	359	235	362	276	362	*	362	*	362	*	362
26'	101	135	149	199	201	245	230	265	248	285	265	305	267	307	267	307	267	307	267	307	267	307
	40	135	59	199	80	266	104	288	131	310	160	332	192	334	226	334	262	334	*	334	*	334
28'	82	109	121	162	164	219	214	246	230	265	246	283	248	285	248	285	248	285	248	285	248	285
	32	109	48	162	65	219	85	268	107	288	132	308	158	310	187	310	217	310	*	310	*	310
30'	90	100	133	136	181	177	230	215	247	230	264	232	266	232	266	232	266	232	266	232	266	
	90	100	40	133	54	181	70	236	89	269	109	287	132	290	156	290	182	290	210	290	*	290
32'	75	83	111	113	151	148	197	187	232	216	248	217	250	217	250	217	250	217	250	217	250	
	75	83	33	111	45	151	59	197	75	250	92	270	111	272	131	272	154	272	177	272	203	272
34'	63	70	93	95	127	125	167	158	211	195	233	204	235	204	235	204	235	204	235	204	235	
	63	70	28	93	38	127	50	167	63	211	78	254	94	256	112	256	131	256	151	256	173	256
36'	53	79	81	108	106	142	135	180	167	220	193	222	193	222	193	222	193	222	193	222		
	53	79	32	108	42	142	54	180	66	222	80	241	96	241	112	241	130	241	149	241		
38'	45	68	93	91	122	116	155	143	191	174	210	183	210	183	210	183	210	183	210			
	45	68	36	122	46	155	57	191	69	229	82	229	97	229	112	229	129	229				
40'	39	58	80	79	105	100	134	124	166	151	198	174	200	174	200	174	200	174	200			
	39	58	31	105	40	134	49	166	60	201	71	217	84	217	98	217	112	217				
42'	34	51	70	91	116	108	144	131	175	157	190	166	190	166	190	166	190					
	34	51	35	116	43	144	52	175	62	207	73	207	85	207	98	207						
44'	29	44	61	80	102	95	126	115	154	138	177	158	182	158	182	158	182					
	29	44	30	102	38	126	46	154	55	184	64	198	75	198	86	198						
46'	39	53	70	90	111	101	135	121	162	143	174	151	174	151	174							
	39	53	40	135	48	162	57	189	66	189	76	189										
48'	34	47	62	79	99	90	120	108	144	127	161	145	167	145	167							
	34	47	29	99	36	120	43	144	50	169	59	181	68	181								
50'	30	42	55	70	88	80	107	96	128	113	148	132	159	139	160							
	30	42	32	107	38	128	45	151	52	173	60	174										

Table Footnotes

- * Indicates total load (TL) value controls.
- Red numbers refer to 115% total load (TL).

See Load Table Instructions and General Notes on page 6.

8' ON-CENTER ROOF SPAN TABLE

Red-I90HS™ Joist, 8' On-Center Roof Span

Red-I90HS™ Joist Depth	12 PSF Dead Load	14 PSF Dead Load	16 PSF Dead Load
16"	27'-0"	26'-0"	24'-5"
18"	29'-9"	28'-5"	26'-7"
20"	32'-7"	31'-0"	28'-11"
22"	35'-3"	33'-7"	31'-4"
24"	38'-0"	36'-3"	33'-9"
26"	40'-2"	38'-9"	36'-3"
28"	41'-11"	40'-4"	37'-10"
30"	43'-7"	42'-0"	39'-0"
32"	45'-3"	42'-2"	39'-0"

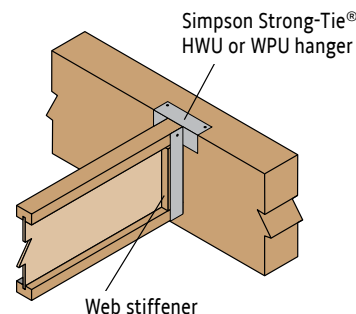

Table is based on:

- Uniformly loaded, simple-span joists
- Red-I™ joists spaced at 8' on-center
- Spans limited by total load deflection of L/180
- Spans reflect 125% duration of load adjustment
- Roof live load of 20 psf with live load reductions applied per 2012 IBC Section 1607.12.2
- Roof slopes of ¼" per foot

General Notes

- Span is defined as horizontal clear distance between inside face of beam/wall supports.
- Reaction based on 3" minimum bearing length and web stiffeners. See web stiffener information on page 16.
- **Bold italic** numbers indicate span may be increased by one foot when HWU hanger is used.
- Fill all nail holes in hanger. Use 10d (3") common nails into joists and 16d (3½") common nails into header.

Typical Floor System

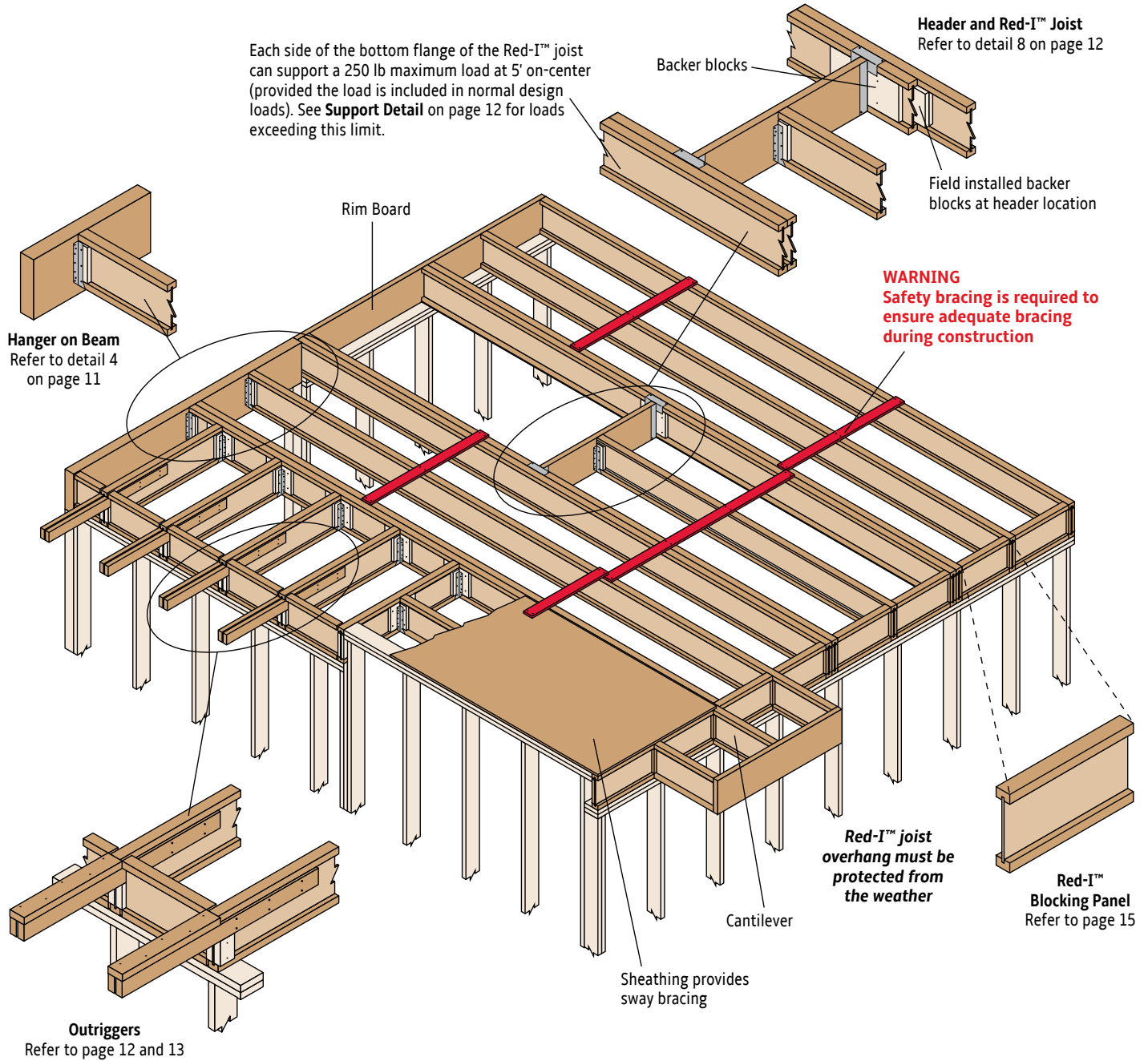

General Notes

- Details shown on pages 10–14 are conceptual. Attachments and connections shall be made to the supporting structure in accordance with the specific design requirements.
- Rim board or Red-I™ blocking panels (or an equivalent alternative) must always be used to prevent rollover and to provide structural attachment of the deck sheathing to the supporting structure in accordance with the specific design requirements.

See **Red-I™ Joist Installation Guide**
(available online at www.RedBuilt.com)
for additional installation guidelines.

1 Nailing Red-I™ Joist to Bearing Plate

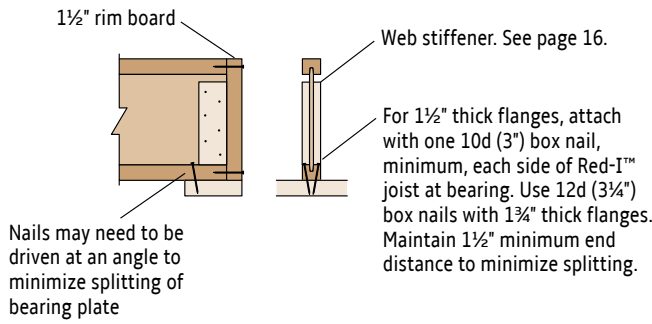

2 Hanger on Stud Wall

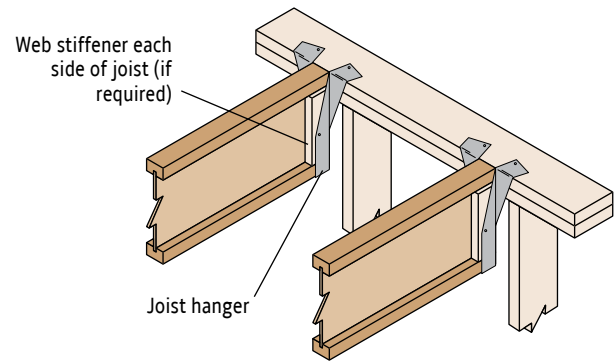

The potential for top plate rotation may reduce hanger capacities. Contact RedBuilt for assistance.

3 Hanger on Ledger

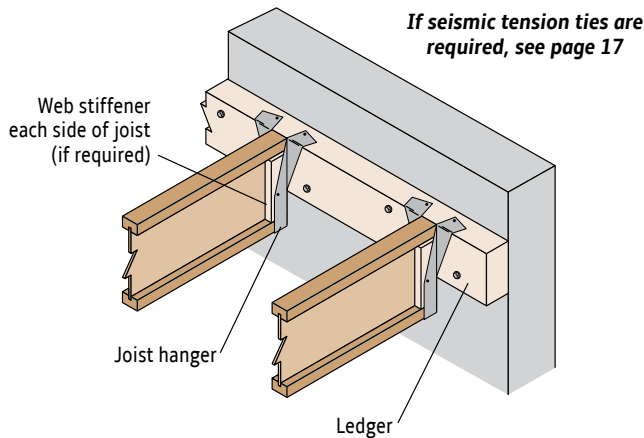

4 Hanger on Beam

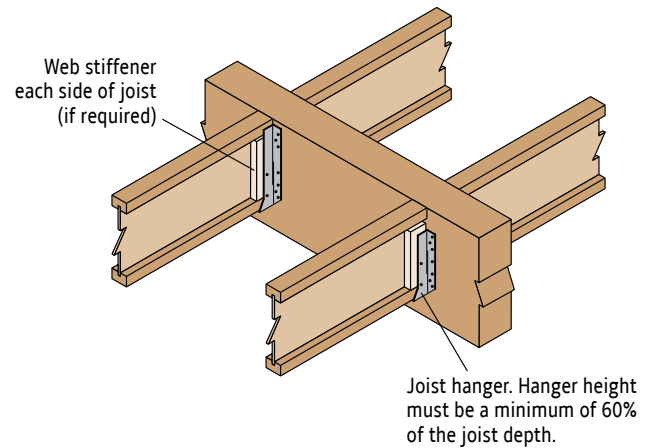

Web stiffeners are required if the sides of the hanger do not laterally support at least 3/8" of the Red-I™ joist top flange.

5 Hanger on Steel Beam

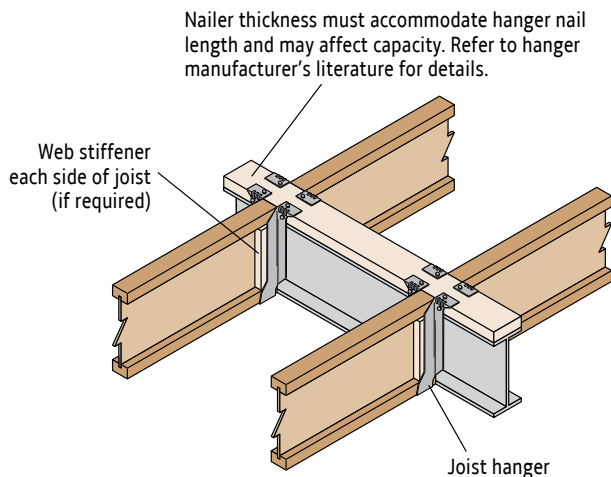

6 Hanger on Masonry Wall

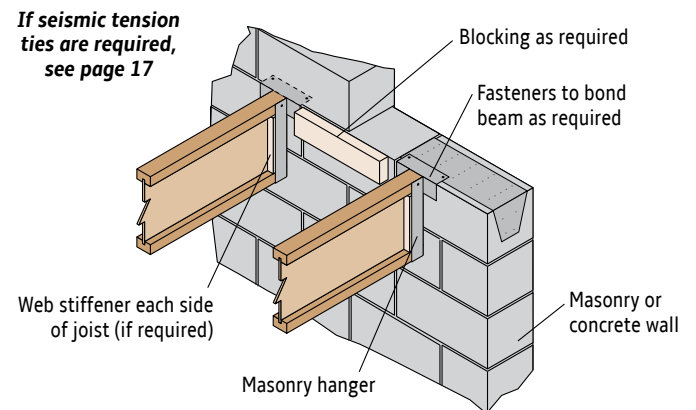

Traditional masonry hangers will not support construction loads without a minimum amount of cured masonry construction above hanger level. Refer to hanger manufacturer's literature for information on the correct installation and use of masonry hangers.

FLOOR DETAILS

7 Side-Loaded Double Joist (Ladder Framing)

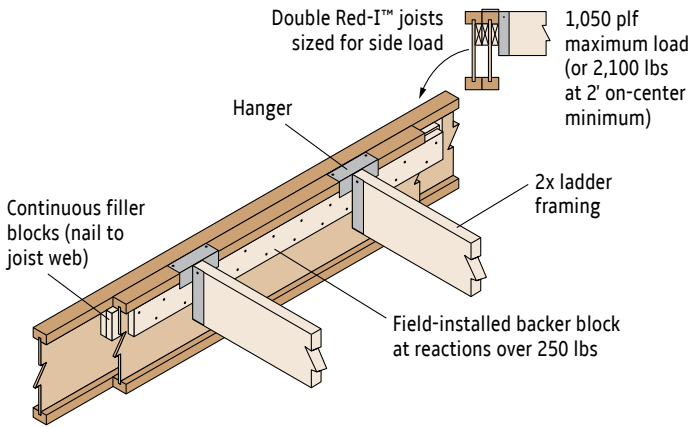

8 Side-Loaded Double Joist (Header Location)

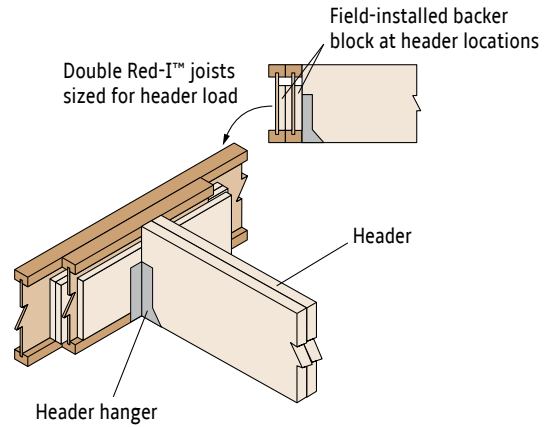

9 Support Detail (For Loads Exceeding 250 lbs)

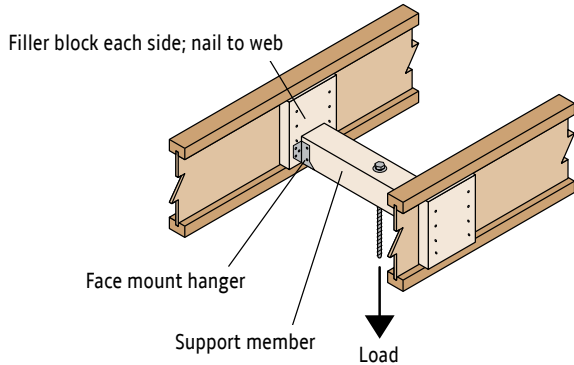

Each side of the bottom flange of the Red-I™ joist can support a 250 lb maximum load at 5' on-center (provided the load is included in normal design loads). Use the detail above for loads exceeding this limit.

For additional information on supporting hanging loads and sprinkler systems, see the [RedBuilt Sprinkler System Installation Guide](http://www.RedBuilt.com) (available online at www.RedBuilt.com).

10 Top-Loaded Double Joist

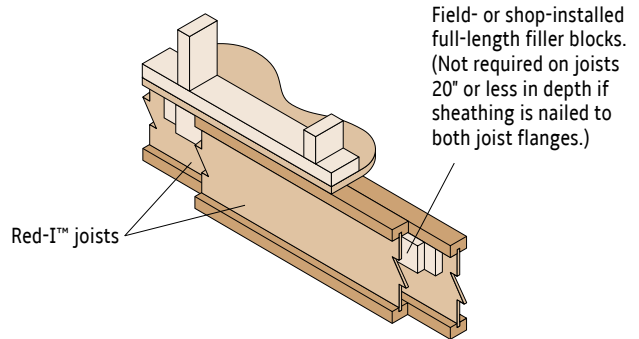

CANTILEVERS AND OUTRIGGERS

11 Red-I™ Joist Cantilever

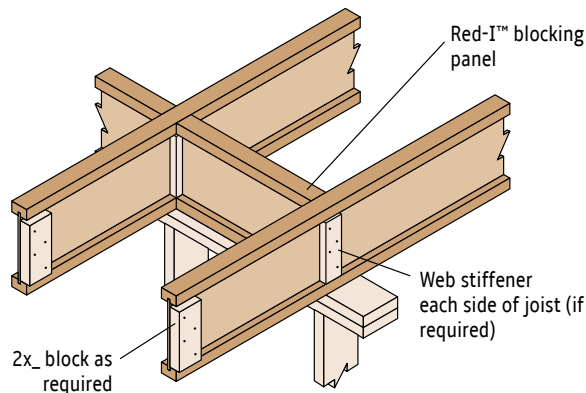

Red-I™ joists are intended for dry-use applications.

12a Cantilevers (Field Assembled Only)

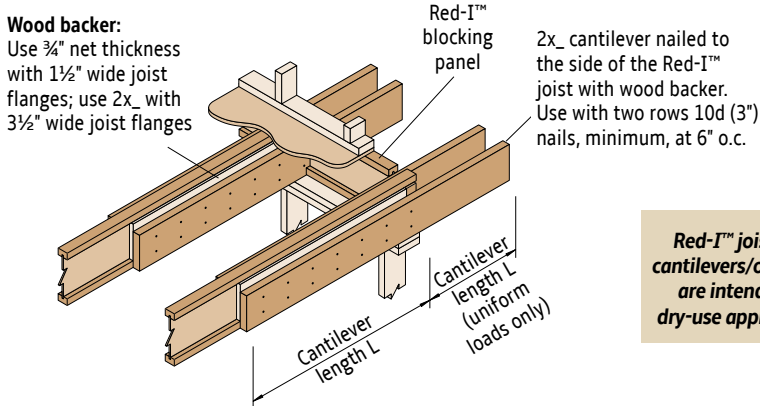

Red-I™ joists and cantilevers/outriggers are intended for dry-use applications.

12b Outriggers (Available as Plant Assembled)

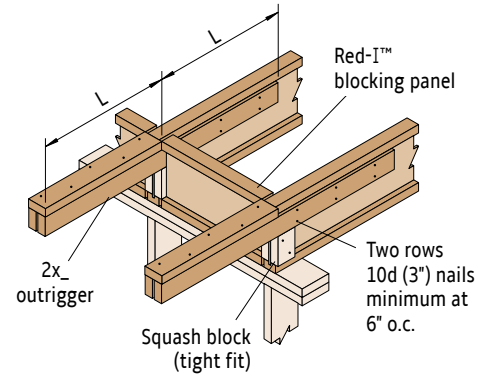

Double application shown in detail 12. Single application is similar. See General Notes below regarding allowable loads.

Double 2x_ Cantilever/Outrigger — Allowable Uniform Loads (PLF)

Cantilever/ Outrigger Length L	Solid Sawn Lumber														
	Two 2x4			Two 2x6			Two 2x8			Two 2x10			Two 2x12		
	Floor	Snow Roof	Non-Snow Roof	Floor	Snow Roof	Non-Snow Roof	Floor	Snow Roof	Non-Snow Roof	Floor	Snow Roof	Non-Snow Roof	Floor	Snow Roof	Non-Snow Roof
24"	342	393	427	393	451	491	393	451	491	393	451	491	393	451	491
30"	219	251	273	384	441	480	384	441	480	384	441	480	384	441	480
36"	152	174	189	323	371	403	378	435	473	378	435	473	378	435	473
42"	111	128	139	237	272	295	374	430	467	374	430	467	374	430	467
48"	77	97	106	181	208	225	289	330	358	371	426	463	371	426	463
54"	54	77	83	143	163	177	227	260	281	337	384	414	368	424	460
60"		62	63	115	132	143	183	209	227	271	308	332	362	410	441
66"			47	95	109	118	151	172	186	222	252	271	296	335	359
72"				79	91	99	126	144	156	186	210	226	246	277	295
78"				68	77	84	107	122	132	157	178	190	207	232	246
84"				56	66	72	92	105	113	135	152	162	177	197	208
90"					57	62	80	91	97	116	131	139	153	169	178
96"					50	54	70	79	85	102	114	121	133	146	153

Cantilever/ Outrigger Length L	RedLam™ LVL														
	Two 2x4			Two 2x6			Two 2x8			Two 2x10			Two 2x12		
	Floor	Snow Roof	Non-Snow Roof	Floor	Snow Roof	Non-Snow Roof	Floor	Snow Roof	Non-Snow Roof	Floor	Snow Roof	Non-Snow Roof	Floor	Snow Roof	Non-Snow Roof
24"	393	451	491	393	451	491	393	451	491	393	451	491	393	451	491
30"	292	441	467	384	441	480	384	441	480	384	441	480	384	441	480
36"	173	277	277	378	435	473	378	435	473	378	435	473	378	435	473
42"	110	177	177	374	430	467	374	430	467	374	430	467	374	430	467
48"	74	119	119	277	417	444	371	426	463	371	426	463	371	426	463
54"	53	84	84	198	317	317	368	424	460	368	424	460	368	424	460
60"		62	62	146	233	233	322	421	456	366	421	458	366	421	458
66"		46	46	110	177	177	246	348	371	365	419	456	365	419	456
72"		36	36	85	137	137	191	288	306	363	410	425	363	418	454
78"				67	108	108	152	242	243	306	339	350	362	417	425
84"				54	87	87	122	196	196	247	283	291	334	346	351
90"					71	71	100	160	160	203	238	244	281	289	293
96"					58	58	83	132	132	168	202	206	238	245	247

Table is based on:

Solid Sawn
 $F_v = 175$ psi
 $F_b = 900$ psi⁽¹⁾
 $E = 1.6 \times 10^6$ psi

RedLam™ LVL
 $F_v = 285$ psi
 $F_b = 2140$ psi⁽²⁾
 $E = 1.6 \times 10^6$ psi

Cantilever/Outrigger Deflection

- 2L/480 at floor live load (live load = 0.80 x total load)
- 2L/240 at roof total load

General Notes

- **Bold Italic** cells indicate a single 2x can be used; use half of the allowable load shown for double 2x members. For all other cells single 2x members are not permitted.
- Members have been evaluated for 300 lb. point load.

⁽¹⁾ Size Factor, C_F , per NDS® Table 4A may be applied
⁽²⁾ For 12" depth; for other depths, multiply by $(12/d)^{0.136}$

ROOF DETAILS

13 Slope Detail

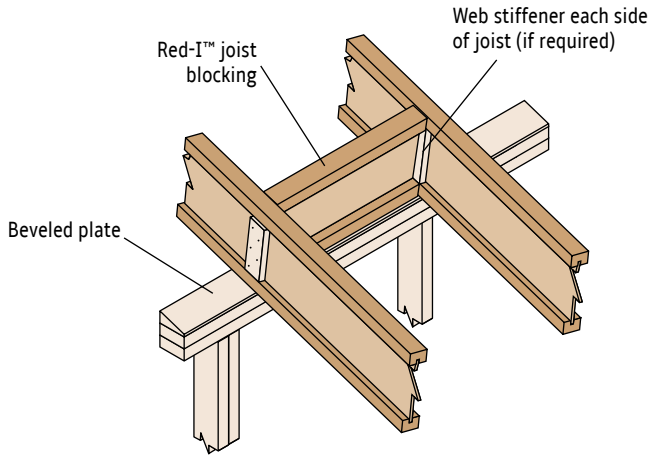

14 Slope Detail at High End

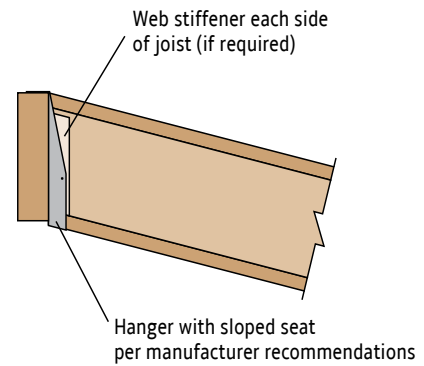

15 Beveled Plate Requirements

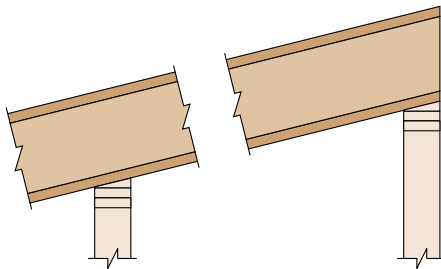

Required Bearing Length	Maximum Slope Without Beveled Plate
1¾"	½" in 12"
3½"	¼" in 12"
5½"	⅛" in 12"

16 Ridge Detail

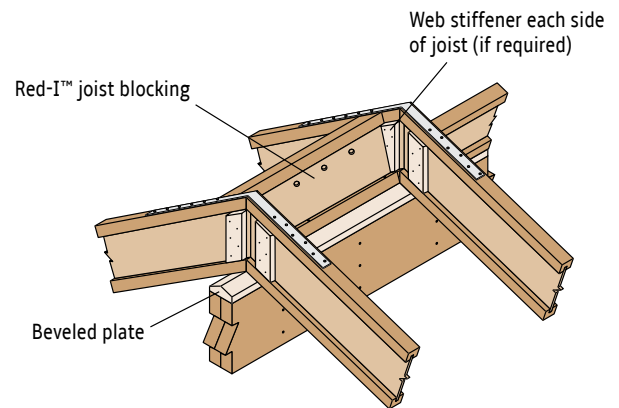

A strap and alternating blocking panels, or two rows of blocking panels, are required for lateral stability.

17 Cantilever with Mansard Framing

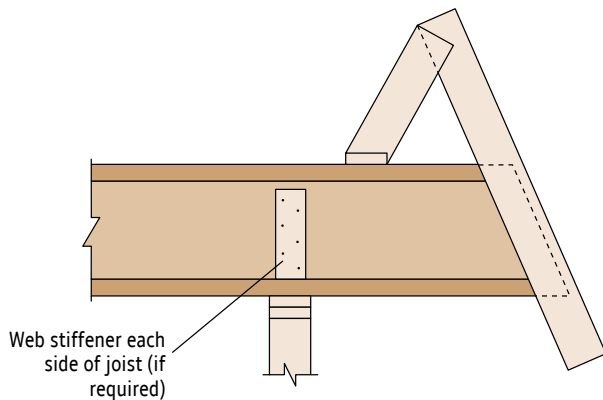

18 Bevel Cut or Fire Cut

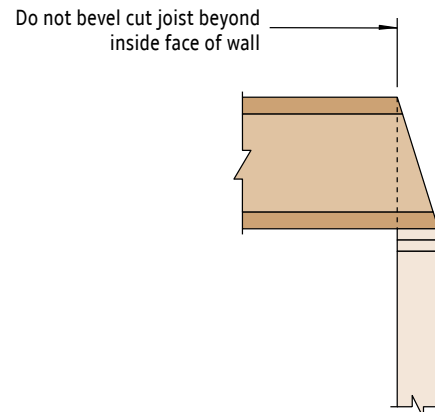

Rim board (up to 24" in depth) is available from RedBuilt and may be used for:

- Shear transfer (nailing must be established by design).
- Vertical load transfer.
- General closure.
- Helping to prevent rollover during joist installation.

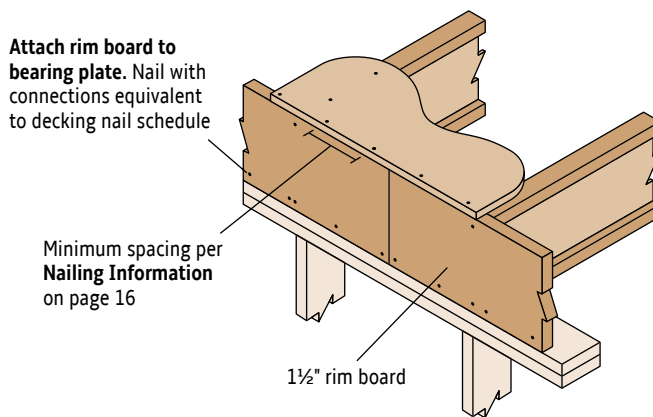

RED-I™ BLOCKING PANELS

Red-I™ blocking panels are available from RedBuilt and may be used for:

- Vertical load transfer.
- General closure.
- Helping to prevent rollover during joist installation.
- Shear transfer (nailing must be established by design).

Shear transfer capacity for each joist is:

- 1,785 plf for Red-I45™ joists;
- 2,255 plf for Red-I65™ and Red-I90™ joists;
- 2,300 plf for Red-I90H™ joists;
- 2,320 plf for Red-I90HS™ joists.

When Red-I™ blocking panels are used for vertical load transfer, values shown in the following table may be used:

Allowable Uniform Vertical Load Transfer (PLF)

Red-I™ Joist Series	Red-I™ Blocking Panel Depth				
	9½"	11⅞"-14"	16"	-	-
I45	2,100	2,100	2,100	-	-
	-	3,050	2,450	1,850	1,200
I65, I90, I90H and I90HS	9½"	11⅞"-14"	16"-20"	22"-24"	26"-30"
	-	3,050	2,450	1,850	1,200

- Loads are for Red-I™ blocking panels or Red-I™ joists as rim board.
- Loads shown may not be increased for duration of load.

Concentrated Vertical Loads

The allowable concentrated vertical loads on Red-I™ blocking panels or rim joist can be determined by using the equation provided below. Loads exceeding the calculated value should be supported by squash blocks.

$$P_{\text{allow}} = W_{\text{allow}} \left[\frac{L_c + 2t_s + 2t_f}{12} \right]$$

Where:

- P_{allow} = Allowable concentrated vertical load (lbs)
- W_{allow} = Allowable uniform vertical load for blocking panel (plf)
- L_c = Bearing length of column on blocking panel (in.)
- t_s = Sheathing thickness (in.)
- t_f = Effective flange thickness:
 ⅞" for Red-I45™, Red-I65™ and Red-I90™ joists;
 1⅛" for Red-I90H™ joists;
 1¼" for Red-I90HS™ joists

Example Calculation

4x4 post applied to 20" Red-I65™ joist through 2⅜" sheathing.

$$P_{\text{allow}} = 2,450 \left[\frac{3.5 + 2(2\frac{3}{32}) + 2(\frac{7}{8})}{12} \right] = 1,365 \text{ lbs}$$

Minimum Red-I™ blocking panel attachment:
 Use 10d (3") box nails (16d [3½"] with I90HS joists) at 6" on-center. When used for shear transfer, nail to bearing plate with connections equivalent to decking nail schedule.

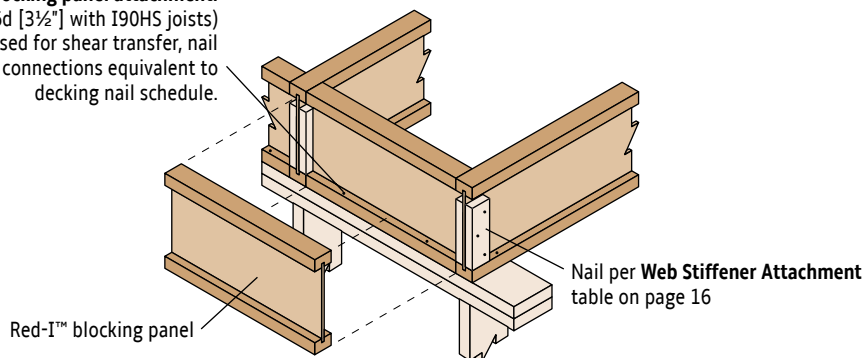

WEB STIFFENERS

The Importance of Web Stiffeners

Web stiffeners are available from RedBuilt in pre-cut sizes and can be installed at the plant on one or both ends upon request. Web stiffeners are an important part of almost all Red-I™ joist installations because they will:

- Stiffen the Red-I™ joist web material and prevent buckling.
- Minimize the bearing length required for the Red-I™ joist.
- Help transfer reaction loads into the Red-I™ joist web.
- Provide stabilization in hangers.

Proper Installation Ensures System Performance

- Web stiffeners must be installed at bearing points as shown in the details below and at points of concentrated loads exceeding 1,500 lbs.
- Web stiffeners are required on joists 20" and greater in depth.
- Web stiffeners are available from RedBuilt and typically have the maximum gap shown below. Verify that hanger nails adequately engage the web stiffener.
- Gap must be at top for all bearing conditions. For concentrated loads, the gap must be at the bottom (see details below).

Web Stiffener Attachment — Nail Quantities

Joist Depth	Red-I45™	Red-I65™	Red-I90™ and Red-I90H™		Red-I90HS™
	8d (0.113" x 2½") Nails		16d (0.135" x 3½") Nails		
	End or Intermediate	End or Intermediate	End	Intermediate	End or Intermediate
9½"	3	–	–	–	–
11⅞"	3	3	3	3	4
14"	3	5	3	3	6
16"	3	6	4	4	6
18"	–	7	4	4	8
20"	–	8	5	5	10
22"	–	9	6	11	10
24"	–	10	6	13	12
26"	–	11	7	14	14
28"	–	12	8	15	14
30"	–	13	8	17	16
32"	–	–	–	–	18

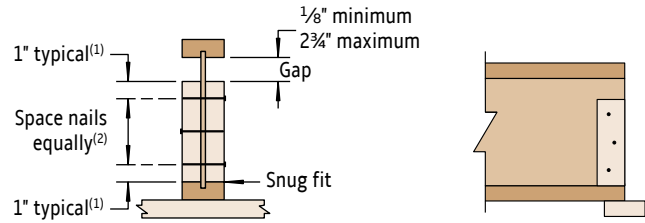

- (1) 1½" (typical) with 2x4 solid sawn lumber web stiffeners.
 (2) Nails may be driven from one side only.

Web Stiffener Size and Material

Flange Width	Minimum Web Stiffener Size	Web Stiffener Material
1¾"	⅝" x 2⅝"	Sheathing (with face grain vertical) that meets the requirements of PS1 or PS2
2½"	1" x 2⅝"	Sheathing (with face grain vertical) that meets the requirements of PS1 or PS2
3½"	2x4	Construction grade or better

Concentrated Load (No Bearing Wall Below)

If concentrated loads from above exceed 1,500 lbs, install web stiffeners tight to Red-I™ joist top flange. See tables at left for nailing and material requirements.

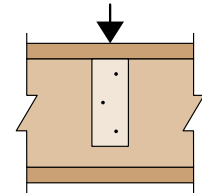

NAILING INFORMATION

Minimum Nail Spacing

Nail Type	Nail Size	Face	RedLam™ LVL			Sawn Lumber	
			Edge			Face	Edge
			Joist Flange	Rim Board, Header, Beam			
8d ⁽¹⁾	Box	0.113" x 2½"	2"	4"	3"	4"	2"
	Common	0.131" x 2½"	2"	6"	3"	6"	2"
10d	Box	0.128" x 3"	2"	6"	3"	6"	2"
	Common	0.148" x 3"	3"	6"	4"	6"	2½"
12d	Box	0.128" x 3¼"	2"	6"	3"	6"	2"
	Common	0.148" x 3¼"	3"	6"	4"	6"	2½"
16d	Box	0.135" x 3½"	3"	6"	4"	6"	2½"
	Sinker	0.148" x 3¼"	3"	6"	4"	6"	2½"
	Common	0.162" x 3½"	4"	8"	8"	8"	4"

- (1) 14 gauge staples may be a direct substitute for 8d nails if a minimum penetration of 1" into the flange is maintained.
- If more than one row of nails is used, offset rows at least ½" and stagger. Use 10d (3") common nails, maximum, and maintain ⅜" minimum edge distance. **Exception: Wind/Seismic Connections** (see page 17).
 - Nailing pattern to be per plans and specifications, and nail spacing should comply with criteria listed on this page.
 - For member stability, nail sheathing to the full length of the member (24" on-center, maximum).

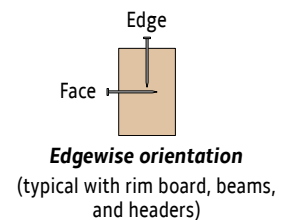
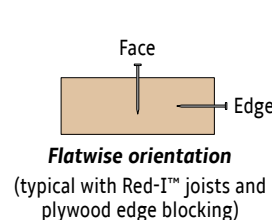
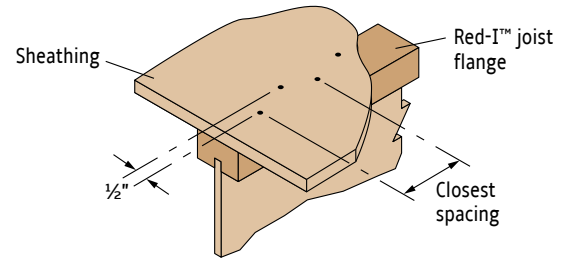

Strap Tension Tie Nailing and Capacities—Allowable Tension Loads*

Design Category	Maximum Ledger Size	Model No.	Strap Length	Embed. Length, l_e		Non-Cracked Concrete			Cracked Concrete			CMU Wall			Max. Allowable Strap Tensile Capacity (lbs)
				Concrete	CMU	Nail Qty.	Nail Size	Tension (lbs)	Nail Qty.	Nail Size	Tension (lbs)	Nail Qty.	Nail Size	Tension (lbs)	
Wind and SDC A-B	4x	PAI18	18½"	4"	6"	9	10d x 1½"	1,820	9	10d x 1½"	1,820	9	10d x 1½"	1,055	NA
		PAI23	23¾"	4"	6"	14	10d x 1½"	2,835	12	10d x 1½"	2,360	14	10d x 1½"	1,805	NA
		PAI28	29"	4"	6"	16	10d x 1½"	3,370	12	10d x 1½"	2,360	16	10d x 1½"	2,705	NA
		PAI35	35"	4"	6"	18	10d x 1½"	3,370	12	10d x 1½"	2,360	18	10d x 1½"	2,815	NA
		MPAI32	32"	5½"	5½"	16	10d x 1½"	2,355	—	—	—	16	10d x 1½"	2,355	—
		MPAI44	44"	5½"	5½"	24	10d x 1½"	2,865	—	—	—	24	10d x 1½"	2,865	—
SDC C-F	4x	PAI18	18½"	4"	6"	9	10d x 1½"	1,820	9	10d x 1½"	1,820	9	10d x 1½"	1,055	4,180
		PAI23	23¾"	4"	6"	14	10d x 1½"	2,830	10	10d x 1½"	1,980	14	10d x 1½"	1,805	4,180
		PAI28	29"	4"	6"	20	10d x 1½"	2,830	10	10d x 1½"	1,980	16	10d x 1½"	2,705	5,070
		PAI35	35"	4"	6"	26	10d x 1½"	2,830	10	10d x 1½"	1,980	18	10d x 1½"	2,815	5,070
		MPAI32	32"	5½"	5½"	—	—	—	—	—	—	16	10d x 1½"	2,355	—
		MPAI44	44"	5½"	5½"	—	—	—	—	—	—	24	10d x 1½"	2,865	—

- Allowable loads have been increased for earthquake or wind load durations with no further increases allowed.
- Deflection at highest allowable loads for standard installation are as follows: PAI18 = 0.10", PAI23 = 0.158", PAI28 = 0.167", and PAI35 = 0.13".
- Multiply seismic and wind ASD load values by 1.4 or 1.6, respectively, to obtain LRFD capacities.
- Minimum center-to-center spacing is three times the required embedment for PA/HPA's acting in tension simultaneously, where l_e = embedment depth. Standard installation is based on minimum 5" end distance.
- For wall anchorage systems in SDC C-F, the maximum allowable strap tensile capacity shall not be less than 1.4 times the ASD anchor design load.
- Nail quantities are based on Douglas fir (DF) or equivalent specific gravity of 0.50 or better. For use on spruce-pine-fir (SPF) or hem fir (HF), nail quantities must be increased by 1.15 to achieve allowable loads.

- Structural composite lumber beams have sides that show either the wide face or the lumber strands/veneers. Values in tables reflect installation in the wide face.
- Concrete shall have a minimum concrete strength (f'_c) of 3,000 psi. Minimum f'_m is 1,500 psi for masonry.
- Use 10d x 1½" nails when installing directly to framing. When installing over wood structural panel sheathing, use 2½" minimum nail lengths for ½" nominal sheathing.
- **Nails:** 10d nails = 0.148" diameter by 3" long;
10d x 1½" nails = 0.148" diameter by 1½" long.
- MPAI straps require 3½" flanges, PAI straps require 2½" flanges.
- See hanger manufacturer for installation information.

* Information adapted from Simpson Strong-Tie® catalog Wood Construction Connectors 2013-2014, p.127.

19 Wall Tension Tie With Straps

For 2½" or wider Red-I™ joists.

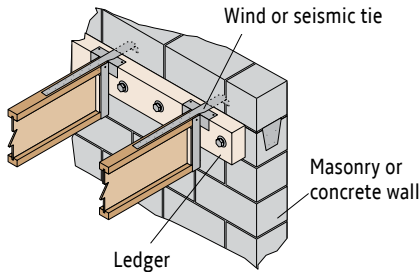

20 Wind or Seismic Tie at Butting Joists

Tension straps must have a minimum nail spacing of 3" on-center per row, with a minimum of ⅜" between rows and maximum nail diameter of 0.148" (10d common).

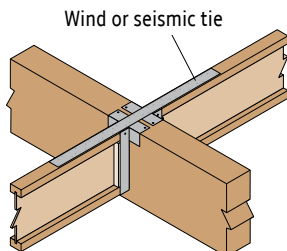

See strap manufacturer's literature for allowable loads.

21 Wall Tension Tie — HD Connections

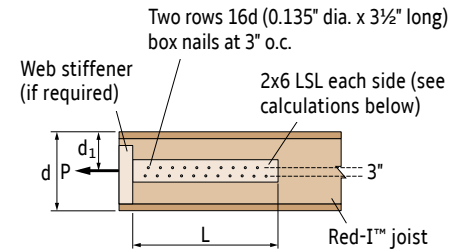
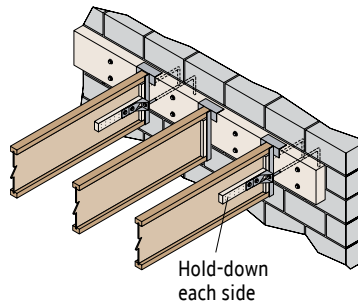

To calculate the length of the LSL block (to transfer shear to joist flange):

$$1. \text{ Find } L_1 = \left[\frac{0.75 (KP)d_1}{C_D V_A - [V_{DL} + (0.75V_{LL})]} \right]$$

$$2. \text{ Find } L_2 = \frac{3}{2} (n) + 3, \text{ where } n = \frac{P}{V_n C_D}$$

3. Compare L_1 and L_2 . Use maximum of the two values for the length of the the LSL block.

- C_D = Load duration factor
- d_1 = Distance to axial load (in.) from top of joist
- L_1, L_2 = Length of block (in.)
- K = 0.6 for wind; 0.7 for seismic (accounts for strength-based load)
- n = Number of nails
- P = Axial load (lbs)
- V_A = Allowable shear load (lbs) for Red-I™ joist (see page 5)
- V_{DL} = Shear load due to gravity dead load (lbs)
- V_{LL} = Shear load due to gravity live load (lbs)
- V_n = Nail shear capacity; see table below

16d Nail Shear Capacity

Red-I™ Web Thickness	V_n (100%) in lbs
⅜"	107
7/16"	124
½"	142

Fire Assembly Details

For Fire Assemblies and other construction-related fire information, please refer to resources on our website at www.RedBuilt.com.

Sound Assemblies and Noise Measurement

The ability of a wall or floor/ceiling system to reduce airborne sound transmission is measured using ASTM E90, and reported using the ASTM E413 Sound Transmission Class (STC) rating system. The ratings listed below—originally developed by the Acoustical and Insulation Materials Association and now considered a standard throughout the industry—are a practical reference for a range of STC numbers. In general, the higher the number, the better the acoustical performance. It is important to note that this table is valid only for a given level of background noise and should be used only for generalized comparisons.

Floor/ceiling systems can also be rated for impact noise transmitted through an assembly. Ratings are determined using the ASTM E492 Impact Insulation Class (IIC) system, and like STC ratings, a high IIC rating indicates significantly reduced impact noise.

STC Ratings

25	Normal speech can be understood quite clearly
30	Loud speech can be understood fairly well
35	Loud speech audible but not intelligible
42	Loud speech audible as a murmur
45	Must strain to hear loud speech
48	Some loud speech barely audible
50	Loud speech not audible

Testing

The acoustical assemblies provided below have been tested and rated by recognized acoustical laboratories, and the ratings shown are well within the acceptable range for multi-family buildings. However, in order to achieve these ratings, precautions should be taken to prevent flanking noise and sound leaks, and to ensure that actual construction conforms to the assembly shown.

22

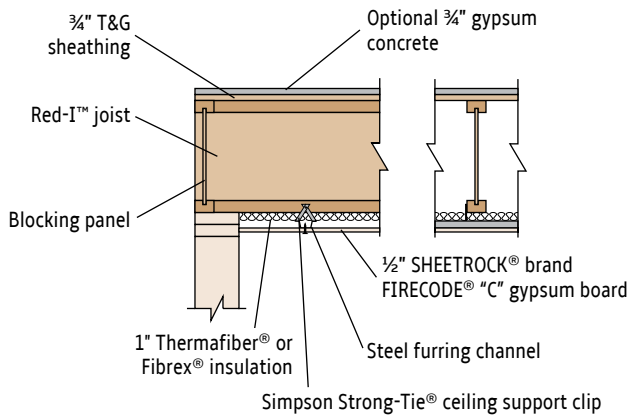

Without Gypsum Concrete	With Gypsum Concrete
STC = 47	STC = 59
Pad and carpet IIC = 54	Pad and carpet IIC = 54
Cushioned vinyl IIC = 43	Cushioned vinyl IIC = 43

23

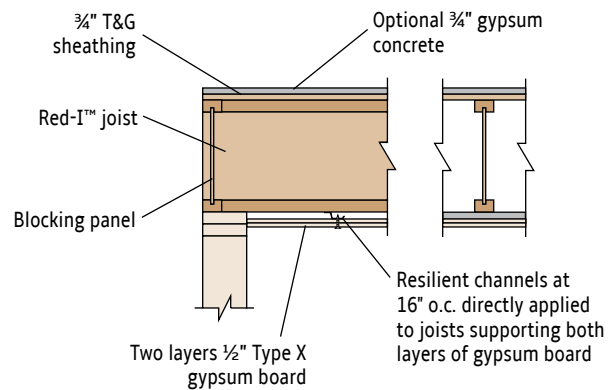

Without Gypsum Concrete	With Gypsum Concrete
STC = 50	STC = 58
Pad and carpet IIC = 60	Pad and carpet IIC = 54
Cushioned vinyl IIC = 45	Cushioned vinyl IIC = 46
Granit Acoustiflor® IIC = 51 ⁽¹⁾	Granit Acoustiflor® IIC = 54 ⁽¹⁾

(1) Requires two layers of 5/8" Type X gypsum board with one layer of 3/2" thick batt insulation.

24

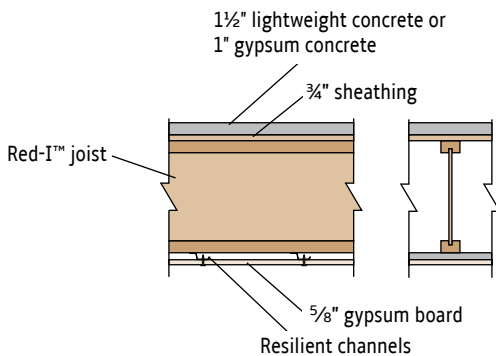

Laboratory Test

STC = 57
G&H No. USDA-11xST

25

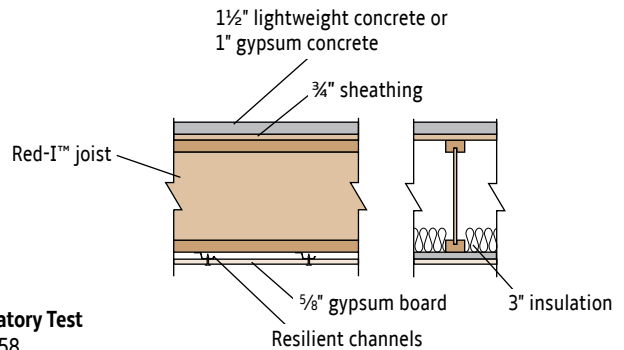

Laboratory Test

STC = 58
With pad and carpet IIC = 77
With vinyl tile IIC = 50
G&H No. USDA-11xST

RED-I JOIST™ ALLOWABLE HOLES

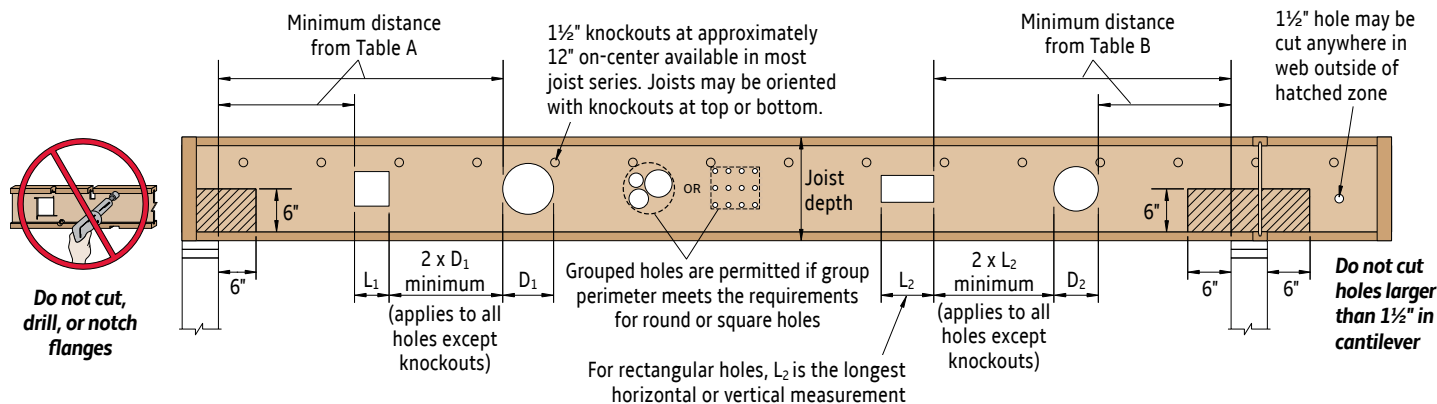

Joist Depth	Joist Series	TABLE A: End Support or Simple Span										TABLE B: Intermediate or Cantilever Support										
		Minimum distance from edge of hole to inside face of nearest support										Minimum distance from edge of hole to inside face of nearest intermediate or cantilever support										
		○ Round Hole Size										○ Round Hole Size										
		2"	4"	6"	8"	10"	12"	14"	16"	18"	20"	2"	4"	6"	8"	10"	12"	14"	16"	18"	20"	
		□ Square or Rectangular Hole Size										□ Square or Rectangular Hole Size										
		1.25"	2.5"	4"	5"	6"	7"	8.5"	9.5"	10.5"	13"	1.25"	2.5"	4"	5"	6"	7"	8.5"	9.5"	10.5"	13"	
9½"	I45	1'-0"	2'-6"	4'-0"	-	-	-	-	-	-	-	1'-0"	2'-6"	5'-0"	-	-	-	-	-	-	-	
	I65	1'-6"	3'-0"	5'-0"	-	-	-	-	-	-	-	1'-6"	4'-0"	6'-6"	-	-	-	-	-	-	-	
	I90	2'-0"	3'-6"	5'-6"	-	-	-	-	-	-	-	3'-0"	5'-6"	8'-0"	-	-	-	-	-	-	-	
117/8"	I45	1'-0"	2'-0"	3'-6"	5'-0"	-	-	-	-	-	-	1'-0"	2'-0"	4'-0"	6'-6"	-	-	-	-	-	-	
	I65	1'-6"	3'-0"	4'-6"	6'-6"	-	-	-	-	-	-	1'-0"	3'-0"	5'-6"	8'-6"	-	-	-	-	-	-	
	I90 / I90H	1'-6"	3'-6"	5'-6"	7'-0"	-	-	-	-	-	-	2'-0"	4'-6"	7'-6"	10'-0"	-	-	-	-	-	-	
	I90HS	2'-0"	4'-0"	6'-6"	-	-	-	-	-	-	-	3'-6"	6'-0"	9'-0"	-	-	-	-	-	-	-	
14"	I45	1'-0"	2'-0"	3'-0"	4'-0"	6'-0"	-	-	-	-	-	1'-0"	1'-0"	3'-0"	5'-0"	7'-6"	-	-	-	-	-	
	I65	1'-0"	2'-6"	4'-0"	5'-6"	8'-0"	-	-	-	-	-	1'-0"	1'-6"	4'-0"	7'-0"	10'-6"	-	-	-	-	-	
	I90 / I90H	1'-0"	3'-0"	5'-0"	6'-6"	9'-0"	-	-	-	-	-	1'-0"	3'-6"	6'-0"	9'-0"	12'-6"	-	-	-	-	-	
	I90HS	2'-0"	4'-0"	6'-0"	8'-0"	-	-	-	-	-	-	4'-0"	6'-6"	9'-0"	11'-6"	-	-	-	-	-	-	
16"	I45 / I65	1'-0"	1'-6"	3'-0"	4'-0"	5'-0"	8'-0"	-	-	-	-	1'-0"	1'-0"	2'-0"	4'-0"	6'-6"	10'-0"	-	-	-	-	
	I90 / I90H	1'-0"	2'-0"	4'-0"	6'-0"	8'-6"	10'-6"	-	-	-	-	1'-0"	1'-6"	4'-6"	8'-0"	11'-0"	14'-6"	-	-	-	-	
	I90HS	2'-0"	4'-0"	6'-0"	8'-0"	10'-0"	-	-	-	-	-	3'-0"	6'-0"	8'-6"	11'-6"	14'-0"	-	-	-	-	-	
18"	I45 / I65	1'-0"	1'-0"	2'-6"	3'-6"	4'-6"	6'-0"	9'-0"	-	-	-	1'-0"	1'-0"	1'-0"	2'-6"	5'-0"	8'-0"	12'-0"	-	-	-	-
	I90 / I90H	1'-0"	1'-0"	2'-6"	5'-0"	7'-0"	9'-6"	12'-6"	-	-	-	1'-0"	1'-0"	2'-6"	5'-6"	9'-0"	12'-6"	17'-0"	-	-	-	-
	I90HS	2'-0"	4'-0"	6'-0"	8'-0"	10'-0"	12'-0"	-	-	-	-	2'-6"	5'-6"	8'-0"	11'-0"	13'-6"	16'-6"	-	-	-	-	-
20"	I45 / I65	1'-0"	1'-0"	2'-0"	3'-0"	4'-0"	5'-0"	7'-0"	10'-6"	-	-	1'-0"	1'-0"	1'-0"	1'-0"	3'-6"	6'-0"	9'-0"	13'-6"	-	-	-
	I90 / I90H	1'-0"	1'-0"	2'-0"	4'-0"	6'-0"	8'-0"	11'-0"	14'-0"	-	-	1'-0"	1'-0"	1'-0"	3'-6"	7'-0"	10'-6"	14'-6"	19'-6"	-	-	-
	I90HS	2'-0"	4'-0"	6'-0"	8'-0"	9'-6"	11'-6"	14'-0"	-	-	-	2'-0"	5'-0"	7'-6"	10'-6"	13'-6"	16'-0"	19'-6"	-	-	-	-
22"	I65	1'-0"	1'-0"	1'-6"	2'-6"	3'-6"	4'-6"	5'-6"	7'-6"	11'-6"	-	1'-0"	1'-0"	1'-0"	1'-0"	2'-0"	4'-6"	7'-0"	10'-0"	15'-0"	-	-
	I90 / I90H	1'-0"	1'-0"	1'-0"	3'-0"	5'-0"	7'-0"	9'-0"	12'-6"	16'-0"	-	1'-0"	1'-0"	1'-6"	4'-0"	6'-6"	9'-6"	12'-0"	16'-0"	-	-	-
	I90HS	2'-0"	4'-0"	6'-0"	8'-0"	9'-6"	11'-6"	13'-6"	16'-0"	-	-	1'-0"	3'-0"	6'-0"	9'-0"	12'-6"	15'-6"	18'-6"	22'-0"	-	-	-
24"-26"	I65	1'-0"	1'-6"	2'-6"	3'-6"	4'-0"	5'-0"	6'-0"	7'-6"	10'-0"	-	1'-0"	1'-0"	1'-6"	3'-0"	4'-6"	6'-0"	7'-6"	10'-0"	13'-6"	-	-
	I90 / I90H	1'-0"	1'-0"	2'-0"	3'-6"	5'-0"	6'-6"	8'-6"	10'-6"	14'-6"	18'-6"	1'-6"	3'-0"	4'-6"	6'-0"	7'-6"	9'-0"	11'-0"	14'-0"	18'-6"	-	-
	I90HS	2'-0"	4'-0"	6'-0"	7'-6"	9'-6"	11'-6"	13'-6"	15'-0"	18'-0"	-	1'-6"	4'-0"	6'-6"	9'-0"	11'-6"	14'-0"	17'-0"	20'-0"	23'-0"	-	-
28"-32"	I65	1'-0"	2'-0"	2'-6"	3'-6"	4'-0"	5'-0"	6'-0"	7'-0"	8'-0"	10'-6"	1'-0"	1'-0"	1'-6"	3'-0"	4'-6"	6'-0"	7'-6"	9'-0"	11'-0"	13'-6"	-
	I90 / I90H	1'-0"	1'-6"	2'-6"	4'-0"	5'-6"	6'-6"	8'-0"	9'-6"	11'-6"	14'-6"	1'-6"	3'-0"	4'-6"	6'-0"	7'-6"	9'-0"	11'-0"	12'-6"	15'-6"	18'-6"	-
	I90HS	2'-0"	3'-6"	5'-0"	7'-0"	8'-6"	10'-0"	12'-0"	13'-6"	16'-0"	18'-6"	1'-0"	2'-6"	4'-6"	7'-0"	9'-6"	12'-0"	14'-6"	17'-0"	19'-6"	21'-6"	-

General Notes

- Tables are based on maximum allowable uniform loads. **Bold italic** cells indicate 2000 lb. concentrated load spread over two joists has not been considered. Use RedSpec™ software or contact your RedBuilt technical representative if concentrated load check is required.
- Holes may be located vertically anywhere in the web. Leave 1/8" of web (minimum) at top and bottom of hole. **DO NOT cut joist flanges.**
- **Do not cut holes in cantilever without consulting your RedBuilt representative.**
- Knockouts are located in web at approximately 12" on-center; they do not affect hole placement.
- Interpolation between holes sizes shown in the tables is allowed.

How to Use Tables A and B

1. Determine the hole shape and size. For rectangular holes, use the largest dimension. Sizes shown in the tables are hole sizes, not duct sizes.
2. Determine the Red-I™ joist series and depth.
3. Determine the type of support on each side of the hole. If the Red-I™ joist is continuous over a support, use both tables.
4. Find the table cell at the intersection of the Red-I™ joist and the hole.
5. The measurement shown is the minimum distance from the edge of the hole to the inside face of the support.
6. Maintain the minimum required distance from **both** supports.

WARNING: Drilling, sawing, sanding or machining wood products generates wood dust, a substance known to the State of California to cause cancer.

For other hole sizes, hole locations, or loads, use RedSpec™ software or contact your RedBuilt technical representative.

DEFLECTION CRITERIA

RedBuilt™ Recommended Deflection Criteria

Full-scale tests have shown repeatedly that RedBuilt™ products have deflection characteristics that are consistently predictable by calculation, with minimal set after load withdrawal.

The graph below shows that the RedBuilt recommended deflection limit for residential and commercial floors is more restrictive than the minimum of L/360 required by building codes. The floor load portions of the tables shown on pages 7–9 were developed based on the **Commercial Floor Deflection Limit** shown in the graph.

Floors:

- Maximum deflection at live load limited as indicated below
- Movable partition loads need not be considered

Roofs:

- Sloped Roofs—¼" to 12" per foot, maximum deflection L/180 at total load
- Plaster Ceilings—Also check L/360 at live load

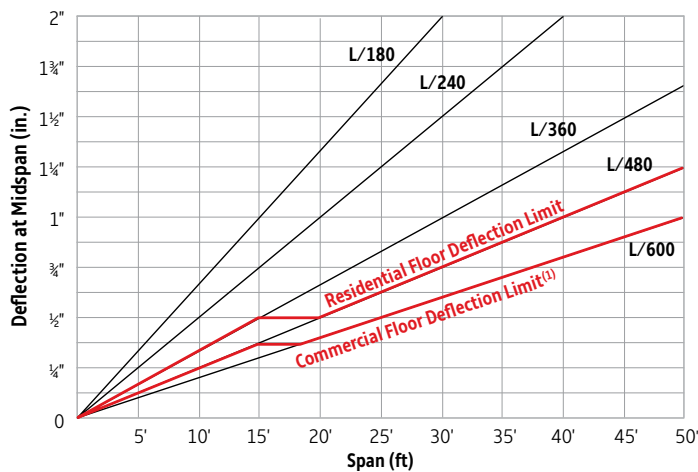

(1) For live load applications greater than 50 psf, check the L/600 deflection limit using a 50 psf live load, and check the code-prescribed deflection limit using the full live load.

Deflection criteria will vary by application. In a roof system, excessive deflection would be unsightly and could cause ceiling cracks and/or drainage problems. Floor systems, however, have entirely different—and usually much more restrictive—deflection requirements due to an occupant’s perception of floor performance and feel.

Deflection Calculations

The deflection characteristics of Red-I™ joists can be closely approximated by analyzing beams using the EI values for flexural deflections shown in the **Design Properties** table on page 5. The EI values selected from the **Design Properties** table must be determined by application (i.e., for roof applications use the EI for joists; for floor applications use the EI for nailed panels or glue-nailed panels).

For uniformly loaded simple spans, the mid-span deflection (in inches) can be calculated as shown below:

Joist Series	Mid-span Deflection Calculation*
Red-I45™	$\Delta = \frac{22.5wL^4}{EI} + \frac{2.67wL^2}{d \times 10^5}$
Red-I65™, I90™, and I90H™	$\Delta = \frac{22.5wL^4}{EI} + \frac{2.26wL^2}{d \times 10^5}$
Red-I90HS™	$\Delta = \frac{22.5wL^4}{EI} + \frac{2.00wL^2}{d \times 10^5}$

* The second function is shear deflection.

Where:

- w = Uniform load in plf
- L = Span in feet
- d = Depth of Red-I™ joist in inches
- EI = Value from the proper column in the **Design Properties** table (page 5)

Example Calculation

Condition:

- 14" Red-I65™ floor joist
- 20' span floor
- Nailed floor sheathing
- 100 plf uniform load

$$\Delta = \frac{22.5 \times 100 \times 20^4}{752 \times 10^6} + \frac{2.26 \times 100 \times 20^2}{14 \times 10^5} = 0.54"$$

In this same example, if the deck was glue-nailed to the Red-I™ joists the deflection would reduce to:

$$\Delta = \frac{22.5 \times 100 \times 20^4}{821 \times 10^6} + \frac{2.26 \times 100 \times 20^2}{14 \times 10^5} = 0.50"$$

SNOWDRIFT LOADING

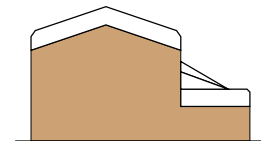
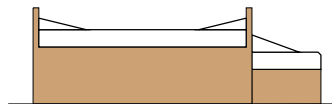
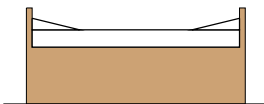

Wind direction, site exposure, and roof type and shape are some of the factors that can dramatically influence the accumulation of snow on a roof structure. ASCE 7 (*Minimum Design Loads for Buildings and Other Structures*) and the applicable building code, as well as other local state and regional codes, provide guidelines for calculating snowdrift loadings on all types of building construction.

Drifts usually occur at locations of discontinuity in a roof, such as at parapet walls, valleys, or where a high roof meets a low roof. Closer on-center spacing or additional support may be required at these locations.

The examples above illustrate potential snowdrift conditions. The project design professional is responsible for determining any additional loads due to snow drifting.

Technical Support Organization and Functions

RedBuilt has four strategically located Design Centers staffed by professional engineers and designers. Their role is to provide technical support and service to our RedBuilt representatives, the professional design community, and the manufacturing plants. Design Center personnel have access to extensive test data, production standards, building code product acceptance criteria, and the most current computer design software.

The Design Centers work closely with our RedBuilt representatives and can provide the following services:

- Review and analysis of potential applications submitted by our RedBuilt representatives
- Drawings showing placement, bearing conditions, dimensions, and installation suggestions
- Custom design of the product
- Assistance in resolving field problems should they arise

This design guide contains technical data and design information frequently required by the design professional when using our products. Because of the variety of possible conditions, the design professional is strongly encouraged to request support from RedBuilt Design Centers through one of our representatives.

Product Application Assumptions

Our warranty is subject to an adequate supporting structure for our products. The design of the entire structure is not the role of RedBuilt, nor can we assume accountability for the full function of the roof or floor system. We can only be responsible for the internal design integrity of our own products, which are structural components of roof and floor systems that are necessarily designed by others.

Our warranty is also subject to continuous lateral support to the compression flange of our products unless specific design provisions account for other lateral support conditions. Continuous lateral support is provided by 8d (2½") nails at 24" on-center (minimum) for Red-I™ joists that are connected to an adequate diaphragm or total lateral strength system.

The magnitude, direction, and location of all design loads are as specified by the building designer. The review of this loading by our personnel is only for purposes of designing our product.

Other application assumptions are referenced on the terms and conditions of our purchase agreement contract.

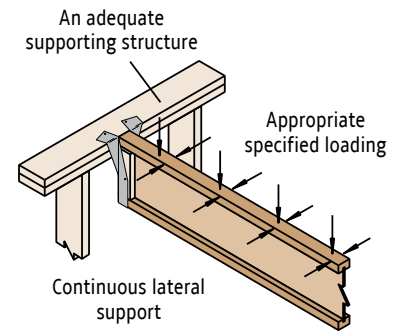

Analysis Procedure—Red-I™ Joists

Using the allowable stresses found in our code approvals, Red-I™ joists are analyzed according to the procedures outlined in ASTM D5055. Bending capacity is determined using the net area of the flanges (rout area deducted) as sole flexural strength, while stiffness considers the contributions of the web material as well. Shear and reaction capacity have been established through product tests, and properties are routinely confirmed through ongoing quality-control testing. Local web buckling in high shear locations, as well as bearing load transfer to the web, may require reinforcement of the web (usually by use of web stiffeners). Web stiffener requirements and fastening details have been established by testing.

The composite nature of the Red-I™ joist results in multiple control mechanisms—all of which are accounted for in testing but are generally unrelated to the shear mechanics of solid joists and timbers. For this reason, ignoring loads near supports is not generally appropriate, and the basic design shear is the vertical shear at the face of the support. In some cases, web confinement and inelastic beam behavior are observed to cause increases in shear strength during testing of members that are continuous over a support. Deflection of Red-I™ joists is closely predicted through flexural and shear deflection analysis, using composite action with the sheathing for nailed or glue-nailed attachments.

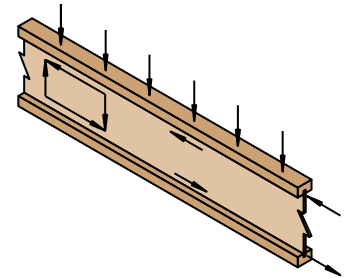

Concentrated and Non-Uniform Loads

For the most efficient use of RedBuilt™ Commercial products resisting concentrated loads, non-uniform loads, and/or in conditions other than simple spans, consult your RedBuilt representative for precise sizing. As a general rule, extra members should be added to the system to carry concentrated loads such as bearing partitions, air conditioners, and other mechanical equipment. Handling concentrated loads in this manner usually provides the most economical system and also helps ensure more uniform deflection.

Q1: What type of certification and quality assurance do Red-I™ joists have?

A1: RedBuilt™ Red-I™ joists are manufactured in accordance with rigorous standards and are monitored by a third party quality control agency (PFS® Corporation). These standards are documented in current evaluation reports in major model building codes, which are also referenced in this guide.

Q2: What types of adhesives are used in Red-I™ joists, and are they waterproof?

A2: Red-I™ joists are manufactured using waterproof, thermoset adhesives such as resorcinol and phenol formaldehyde. These adhesives meet the requirements of ASTM standard D2559.

Q3: What is the level of formaldehyde emissions from the adhesives in your Red-I™ joists?

A3: It is less than 0.10 parts per million (ppm).

Independent third-party testing⁽¹⁾⁽²⁾ shows that products manufactured with these adhesives do not emit significant amounts of formaldehyde. When tested in accordance with the ASTM large-chamber test⁽³⁾, the formaldehyde emissions of these products were below 0.10 ppm, which is below even the most stringent regulatory requirements. In many cases, emissions were so low that they could not be distinguished from background levels of formaldehyde in the fresh air used during testing⁽⁴⁾.

Q4: Are tapered and cambered Red-I™ joists available?

A4: Yes. RedBuilt offers the Red-I65T™ series joist in a single slope, tapered profile to provide minimum roof slopes for drainage. For more details, refer to our [Tapered Joist Design Guide](#) (available at www.RedBuilt.com). A nominal camber can also be built into some Red-I™ joist products (see **Red-I™ Joist Descriptions** on page 4). Contact your RedBuilt representative for more information.

Q5: Do Red-I™ joists meet the requirements set forth in the U.S. Green Building Council's (USGBC) Leadership in Energy and Environmental Design (LEED) standard?

A5: LEED – NC (new construction) is a commonly used building rating system designed to accelerate the development of green building practice. While products such as Red-I™ joists are not LEED certified on an individual basis, they may contribute to point totals for a “whole building” certification. For example, the following items may be viewed as contributors toward points in the LEED rating system:

- RedBuilt offers FSC credits for our Red-I™ joist products as well as other products we manufacture or distribute. Consult your local RedBuilt technical representative for availability.
- The **Low Emitting Materials** section (EQ 4.4) recognizes composite wood that is free from urea-formaldehyde resins. RedBuilt does not use urea-formaldehyde resins in any of its engineered lumber products. Material Safety Data Sheets (MSDS) are available at www.RedBuilt.com.
- RedBuilt™ products may qualify for Regional Materials (MR 5.1 & 5.2) for projects located within a 500 mile radius of Portland, OR.
- Hardware accessories to Red-I™ joists, such as Simpson Strong-Tie® hangers, may qualify for Recycled Content (RC 4.1 & 4.2). For more information visit Simpson's website at www.strongtie.com.

Q6: Are repetitive-member increases allowed in Red-I™ joist design?

A6: No. The product qualification model in ASTM D5055 modifies the resistive-moment values so they closely model wood I-joist moment capacity. However, that procedure does not use a repetitive-member increase, so an increase to the Red-I™ joist moment values shown in this design guide is not applicable.

Q7: Are there special considerations for shear design in Red-I™ joists?

A7: Yes. In wood design, it is common practice to neglect all uniform loads within a distance equal to the joist depth; however, that does not apply to Red-I™ joists at end bearing locations. In addition, it is critical that Red-I™ joists be designed for both reaction and shear at supports.

References:

(1) Structural Board Association Technical Bulletin, TB102 <www.osbguide.com/osbliterature.html>

(2) APA — The Engineered Wood Association <www.apawood.org>

(3) *Determining Formaldehyde Concentrations in Air and Emission Rates from Wood Products Using a Large Chamber*. ASTM E1333

(4) *Technical Report: Structural Wood Panels and Formaldehyde*. APA — The Engineered Wood Association

Q8: What are the deflection criteria most commonly used when selecting Red-I™ joists?

A8: Red-I™ joist deflections must meet all applicable building codes and any criteria specified by the building designer. But as the graph on page 20 shows, the RedBuilt recommended deflection limits for residential and commercial floors are more restrictive than the minimums required by typical building codes.

It is important to note that designing a floor around a deflection limit is often not enough to ensure good floor performance. Individual perceptions of floor vibration vary, and they are influenced by a variety of factors associated with floor construction.

Q9: Are there special considerations when using double Red-I™ joists?

A9: Yes. With double Red-I™ joists, if a load is applied to the side of one member, you must connect the two Red-I™ joists together at the loading point to transfer the load equally into both members. For more specific information, see detail 7 on page 12.

Typically, sheathing is not nailed to both Red-I™ joists, which leaves one joist with an unbraced compression flange. To ensure the lateral stability of both joists when loads are applied from above, the Red-I™ joists must be connected as shown in detail 9 on page 12. Often, a rectangular member may be the simplest option.

Q10: Is the 1½"-thick flange on commercial Red-I™ joists sufficient for the nail penetration required by building code diaphragm tables?

A10: Yes. A 1½"-thick (or thicker) flange meets the fastener penetration requirements stated in building code diaphragm tables such as IBC Table 2306.3.1. For other building codes, calculations per the *2008 AWC Special Design Provisions for Wind and Seismic* consider fastener penetration into the main member and show that a 1½" penetration does not reduce the lateral nail capacity.

Q11: How do I account for snowdrift loading on Red-I™ joists?

A11: Snowdrift loading should be considered by the designer in any snow load area where roof projections and/or changes in roof elevations could allow snow to accumulate. Specific design criteria falls under the jurisdiction of local building codes.

Q12: Does RedBuilt provide guidelines for the installation of Red-I™ joists?

A12: Yes. Installation guides are provided with every Red-I™ joist delivery. Typical construction applications and details can be found in the guide, and particular attention should be given to the handling, storage, safety bracing, and installation instructions. Shop drawings showing job-specific information are also furnished upon request. A copy of our *Red-I™ Joist Installation Guide* can also be downloaded from www.RedBuilt.com.

Q13: Are your Red-I™ joists covered by a warranty?

A13: Yes. RedBuilt warrants that its products will be free from manufacturing errors or defects in workmanship and material. In addition, provided the product is correctly installed and used, the company warrants the adequacy of its design for the normal and expected life of the building. A copy of our [Product Warranty](#) can be found on the back cover of this guide or on our website at www.RedBuilt.com.

Q14: Does RedBuilt provide any fire-rated assembly details?

A14: Yes. RedBuilt provides a number of [fire assembly details](#), which can be downloaded from our website at www.RedBuilt.com.

Q15: How can I contact a RedBuilt representative?

A15: You can find your local RedBuilt representative by calling 1-866-859-6757 or through the [FIND A REP locator](#) on our website at www.RedBuilt.com.

RED-I™ JOIST SPECIFICATIONS

1.0 General

1.1 Scope

This work includes the complete furnishings and installation of all Red-I™ joists, as shown on the drawings herein specified and necessary to complete the work.

1.2 Code Approvals

These products shall be designed and manufactured to the standards set forth in the International Code Council Report No. ESR-2994.

1.3 Related Work Specified Elsewhere

- A. Carpentry and millwork
- B. Glu-laminated members

1.4 Design

A. Products: RedBuilt™ products shall be designed to fit the dimensions and loads indicated on the plans.

B. Design Calculations: When requested, a complete set of design calculations shall be prepared by RedBuilt.

1.5 Submittals

A. Drawings: Drawings showing layout and detail necessary for determining fit and placement in the building shall be provided by RedBuilt.

B. Production: Fabrication and/or cutting shall not proceed until the architect and/or engineer have approved the submittal package.

2.0 Products

2.1 Materials

Flange members, web members and adhesives shall conform to the provisions of ICC-ES Report No. ESR-2994.

2.2 Fabrication

Red-I™ joists shall be manufactured by RedBuilt in a plant listed in the report referred to above and under the supervision of an approved third-party inspection agency.

2.3 Tolerances

Depth: $\pm 1/16$ "
Flange Width: $\pm 1/16$ "

2.4 Identification

Each of the joists shall be identified by a stamp indicating the joist series, ICC-ES report number, manufacturer's name, plant number, date of fabrication, and the independent inspection agency's logo.

2.5 Hardware

Not applicable.

3.0 Execution

3.1 Installation

Red-I™ joists, if stored prior to installation, shall be protected from the weather. They shall be handled with care so they are not damaged. Red-I™ joists shall be installed in accordance with the plans, and any RedBuilt drawings and installation suggestions. Temporary construction loads that cause stresses beyond design limits are not permitted. Safety bracing is to be provided by the installer to keep the Red-I™ joists straight and plumb as required, and to ensure adequate lateral support for the individual Red-I™ joist members and the entire system until the sheathing material is applied.

3.2 Installation Review

Prior to enclosing the Red-I™ joists, the Contractor shall give notification to the RedBuilt representative to provide an opportunity for review of the installation.

3.3 Performance Standards

Products shall be proven by testing and evaluation in accordance with the provisions of ASTM D5055.

3.4 Fire Rating/Sound Rating

Fire and sound ratings are to be established in accordance with the assemblies detailed in ICC-ES Report No. ESR-2994, or the *Directory of Listed Products* published by Intertek Testing Services.

3.5 Warranty

The products delivered shall be free from manufacturing errors or defects in workmanship and material. The products, when correctly installed and maintained, shall be warranted to perform as designed for the normal and expected life of the building.

4.0 Alternates and/or Equals

4.1 Base Bid

Due to the customized detailing and engineering characteristics of the roof and/or floor framing assembly, it is a requirement that Red-I™ joists be used in the base bid.

4.2 Alternate Manufacturers

Other manufacturers' bids are to be listed in the alternate section of your proposal. All framing plans, detailing, and calculations for the alternate bids will be reviewed by the owner, architect, and engineer for structural performance, possible conflicts with related trades, and compatibility with the overall building requirements and building code.

4.3 Alternate Products

Alternate products will only be permitted if written approval and acceptance is obtained by both architect and owner at least seven days prior to the bid date. Any monetary savings that may be realized by using an alternate product shall be forwarded to the owner.

4.4 Acceptable Alternatives

At the discretion of the specifier of record, accepted alternates will be listed on the final addendum prior to the bid date.

Refer to local building codes for live load design requirements.

Composition Roofing

2-15 and 1-90 lb	1.7 psf
3-15 and 1-90 lb	2.2 psf
3-ply and gravel	5.6 psf
4-ply and gravel	6.0 psf
5-ply and gravel	6.5 psf
Insulated Roof Membrane Assembly (IRMA)	
2" thick	13.0 psf
Single-ply roofs (insulation not included)	
Ballasted system	13.0 psf
Mechanically fastened	2.0 psf
Fully adhered	2.0 psf

Douglas Fir Sheathing*

(Based on 36 pcf for plywood, 40 pcf for OSB)

½" plywood	1.5 psf
⅝" plywood	1.8 psf
¾" plywood	2.3 psf
1⅛" plywood	3.4 psf
½" OSB	1.7 psf
⅝" OSB	2.0 psf
¾" OSB	2.5 psf
7⁄8" OSB	2.9 psf
1⅜" OSB	3.7 psf

* For southern pine weights, increase Douglas fir weights by 10%.

Miscellaneous Roofing Materials

Corrugated galvanized steel	
16 ga.	2.9 psf
20 ga.	1.8 psf
22 ga.	1.5 psf
24 ga.	1.3 psf
Asphalt shingles	2.5 psf
Wood shingles	3.0 psf
Clay tile	9.0 to 14.0 psf
Slate (⅜" thick)	15.0 psf

Rigid Insulation (1" thick)

Hemlock	1.2 psf
Cork	0.7 psf
Gold bond	1.5 psf
Polystyrene foam	0.2 psf
Foamglass	0.8 psf
Rigid fiberglass	1.5 psf

Roll or Batt Insulation (1" thick)

Rock wool	0.2 psf
Glass wool	0.1 psf

Floors

Hardwood (nominal 1")	4.0 psf
Concrete (1" thick)	
Regular	12.0 psf
Lightweight	8.0 to 10.0 psf
Gypsum concrete (¾" thick)	6.5 psf
Sheet vinyl	0.5 psf
Carpet and pad	1.0 psf
¾" ceramic or quarry tile	10.0 psf

Ceilings

Acoustical fiber tile	1.0 psf
½" gypsum board	2.2 psf
⅝" gypsum board	2.8 psf
Plaster (1" thick)	8.0 psf
Metal suspension system (including tile)	1.8 psf

To calculate total dead load, use a minimum of 1.5 psf for "miscellaneous" with all dead loads.

Weights of Douglas Fir Framing Members

Nominal Size (in.)	Joist Spacing		
	12"	16"	24"
2x4	1.4 psf	1.1 psf	0.7 psf
2x6	2.2 psf	1.7 psf	1.1 psf
2x8	2.9 psf	2.2 psf	1.5 psf
2x10	3.7 psf	2.8 psf	1.9 psf
2x12	4.4 psf	3.3 psf	2.2 psf
3x6	3.6 plf		
4x6	5.0 plf		
4x8	6.8 plf		
4x10	8.6 plf		
4x12	10.4 plf		

• For southern pine weights, increase Douglas fir weights by 10%

Weights of Sprinkler Lines

Size of Pipe	Schedule 40, Standard Pipe		Schedule 10, Thin Wall Pipe	
	Dry (plf)	Wet (plf)	Dry (plf)	Wet (plf)
1"	1.7	2.1	1.4	1.8
1¼"	2.3	3.0	1.8	2.5
1½"	2.7	3.6	2.1	3.1
2"	3.7	5.2	2.7	4.2
2½"	5.8	7.9	3.6	5.9
3"	7.6	10.8	4.3	8.0
3½"	9.2	13.5	5.0	9.8
4"	10.9	16.4	5.6	11.8
5"	14.8	23.5	7.8	17.3
6"	19.2	31.7	9.3	23.1
8"	28.6	50.8	16.9	40.1
10"	40.5	74.6		

• For additional information on sprinkler systems, see RedBuilt's *Sprinkler System Installation Guide* (available online at www.RedBuilt.com)

Approximate Weights of RedBuilt™ Products

	Series	PLF Weight
	Trusses	Red-L™, Red-LT™
Red-W™		4.50-5.25
Red-S™		4.75-5.75
Red-M™		8.00-9.00
	Red-H™	10.00-12.00
Joists	Red-I45™	2.2-3.5
	Red-I65™	3.0-5.8
	Red-I90™	4.2-6.6
	Red-I90H™	4.6-7.1
	Red-I90HS™	6.0-9.1

Structural Composite Lumber	Density (pcf)
2.0E RedLam™ LVL	42
LSL	45

• PLF Unit Weight = (density) x (width) x (depth)



Specifying Made Simple.

Specifying RedBuilt™ products for your projects just got easier with RedSpec™ single-member sizing software from RedBuilt.

RedSpec™ is a convenient, user-friendly design program that lets engineers and architects quickly and efficiently create floor and roof design specifications using Red-I™ joists, RedBuilt™ open-web trusses, RedLam™ LVL, glulam beams and dimensional lumber for a variety of commercial and multi-family construction applications.

RedSpec™ was developed—and is supported—by a team of industry veterans with decades of experience.

RedSpec™ single-member sizing software is user friendly, easy to learn, and provides a suite of tools and features that make specifying and designing simpler:

- Multiple live- and dead-loading configurations
- Solid-sawn lumber and glulam sizing capabilities
- FloorChoice™ Floor Performance Rating System
- Simple tab-driven interface
- Integrated hardware selection
- Intuitive span inputs
- Best systems analysis
- Hole analysis
- Project tree folder
- Built-in PDF printing
- Local technical assistance

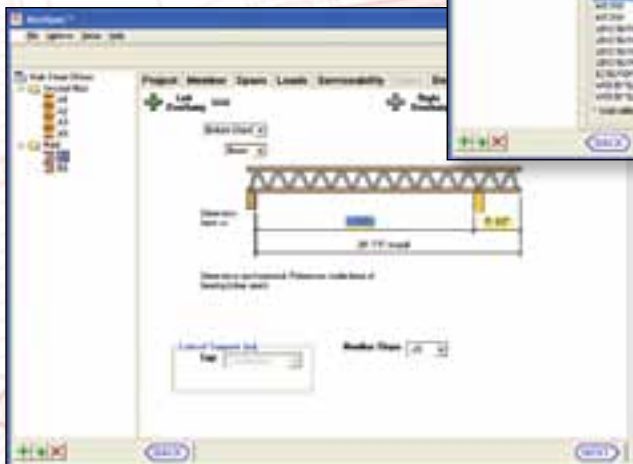
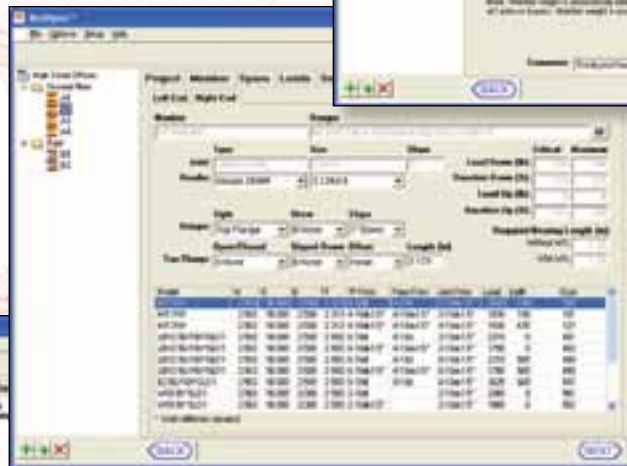
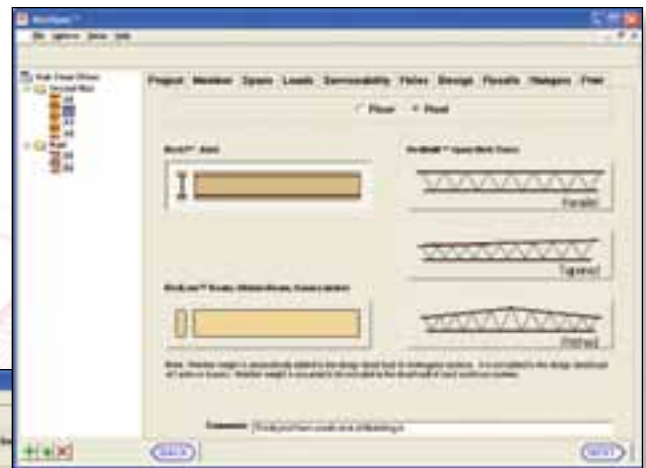

Ready to simplify your life? Contact your RedBuilt representative for more information or visit RedBuilt.com for a free RedSpec™ software download.

Handwriting practice area consisting of 30 horizontal lines.



SERVICE AND SUPPORT YOU CAN COUNT ON.

RedBuilt is committed to creating superior structural solutions. How? By offering efficient structural building products supported by a broad range of services.

- Our team of RedBuilt representatives—one of the industry's largest—isn't afraid to get its hands dirty. We can help with technical information, installation questions or code compliance.
- At RedBuilt, our goal is to help you build solid and durable structures. A limited warranty for our products is in effect for the expected life of the building.
- Call us with a problem that you believe may be caused by our products, and our representative will contact you within one business day to evaluate the problem and help solve it—**GUARANTEED**.



CONTACT US

1.866.859.6757

www.redbuilt.com

200 E. Mallard Drive, Boise, ID 83706

P.O. Box 60, Boise, ID 83707

REPRESENTATIVE INFORMATION

