



MOISTURE AND DURABILITY

A Wood-Frame Building Performance Fact Sheet



It's a common misconception that water is wood's enemy. That's not necessarily the case.

Wood buildings in rainy or humid places can have long-term, problem-free performance. It's all a matter of knowing how to manage water when designing and constructing with wood-based building products.

Some facts on wood and water

To begin with, water alone doesn't harm wood. Water can, however, support life forms that can eat wood. But it takes a lot of water over a long period of time before wood becomes attractive to damaging organisms.

Wood is, in fact, less prone to permanent damage from the odd soaking than other common building materials, such as plaster, drywall, non-wood floor coverings, acoustic ceiling tile, and furnishings. Wood can safely absorb and release large quantities of water. As a rule, the only part of a building that needs to be totally impervious to water — shedding it if possible, but remaining waterproof under ponding — is the outer layer of the building envelope, particularly the roof membrane. If the building skin sheds water properly, we can trust that other building components within it needn't be waterproof too.

Moisture content (MC) is a measure of how much water is in a piece of wood relative to the wood itself. We calculate MC by dividing the weight of the water in a given sample of wood by the weight that wood would have if it were totally dry. For example, 200% MC means a piece of wood has twice as much of its weight due to water than to wood — in other words, it's 2/3 water.

Two key numbers to remember are **19%** and **28%**. Wood is considered dry if its MC is 19% or less. At around 28% MC, wood achieves *fibre saturation*, an important benchmark for both shrinkage and decay. Decay fungi will generally not grow unless wood moisture content is at or above fibre saturation. And wood doesn't shrink or swell when it is above fibre saturation. As wood dries below 28% MC, it shrinks slightly. The bulk of this variation can be avoided by purchasing *dry* (also called *seasoned*) lumber, which has been pre-dried to no more than 19% MC and hence pre-shrunk. Lumber above 19% MC is called *green* or *unseasoned*.



This modern condominium in Vancouver, Canada includes tried-and-true moisture protection strategies used throughout history in rainy climates all over the world. A well-built sloping roof with minimal penetrations and generous overhangs is truly effective at shedding rain, thus protecting the other building components.



When wood gets too wet for too long



Wood is a natural, biodegradable material. The organisms that eat it, however, usually can't do so without water. Termites and fungi, for example, need moisture to live.

Wood decay, or rot, results from fungi — a class of organisms, neither plant nor animal, that reproduces via spores. Fungal spores are always present in the air, so decay may begin whenever temperature and moisture simultaneously reach critical thresholds for the germination of those spores. In normal construction service, temperature and moisture content of wood components are well below the safety limits for decay fungi to grow. It is when building failure lets large amounts of water enter construction assemblies that wood runs a risk of decay.

Though several species of fungi grow on wood, only a few destroy it. Under certain conditions, wood-rotting fungi grow quite quickly and may rapidly affect the appearance and the strength of wood products. Some moulds can also grow on wood, but they don't harm it. Moulds are another type of fungi which grow in buildings on a wide range of organic substrates: not only wood but also food, paint, paper, textiles or even dust. These organisms cause surface stains, odours, and occasional allergic reactions in humans. When seen on building surfaces, they are best treated as indicators — their presence betrays a moisture problem that needs addressing.

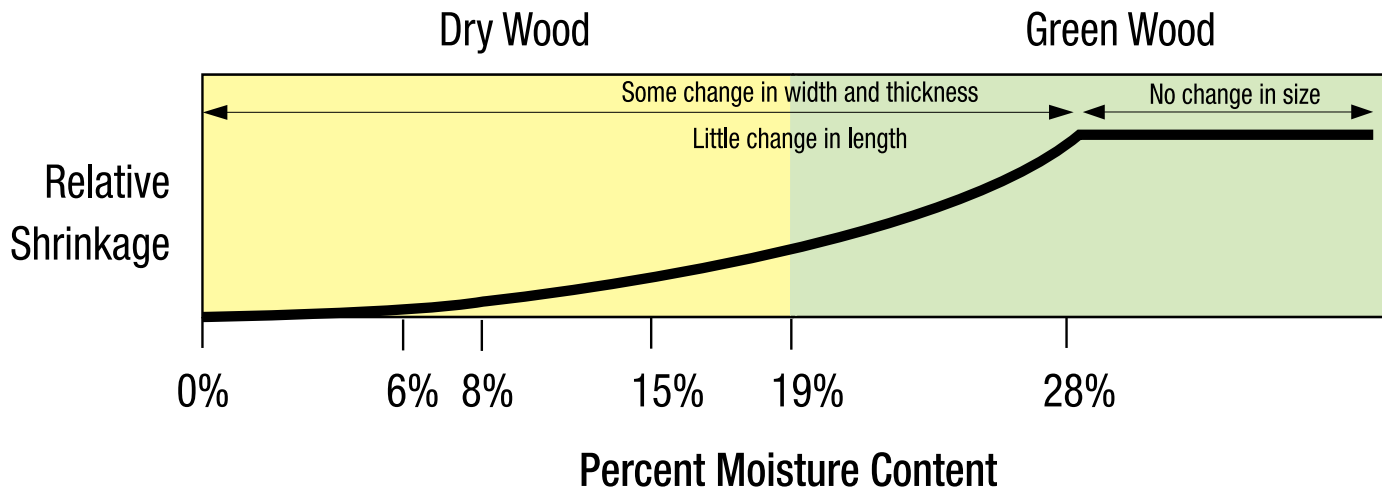

Dry lumber has already done most of its shrinking, making construction easier. Lumber can either be dried naturally in the air (and then stamped "S-DRY" for surfaced-dry), or it can be dried with heat, in a kiln (stamped "KD" or "S-DRY").

Making a durable wood building



Long-lasting wood buildings can be found in all climates around the world. In rainy places, historic architectural styles usually involve elements that shed water, like wide overhangs and sloping roofs. These intuitive design features work very well in protecting the underlying wood framing — which, like almost all construction materials, is meant to stay dry.

Modern buildings may include many features that are a challenge for water protection: roof penetrations, many windows, flat roofs, balconies, and complicated building shapes. These design elements must be carefully detailed and constructed to keep out rain. Building codes and standards generally leave weather protection to designers and builders. When everyone involved in building and occupying a structure follows good practice, wood buildings perform very well, over a very long time.

Rain is the most important liquid water source to control; but plumbing leaks also cause trouble, and must be found and repaired at once.

Water vapour may be a source of problematic moisture in buildings. When water vapour contacts a cool surface it can condense back to liquid. On cold days, warm indoor air moving through cracks in the wall cools as it encounters outer wall layers, which can cause water vapour carried by the air to condense within the wall. On hot days, humid air moving into an air-conditioned house may cause the same problem in reverse. While the amounts of potential condensed water are small, building design should include features to prevent condensation. The solution is proper control of air and vapour flow through the building skin. Building codes and standards typically provide guidance on the use of air barriers and vapour barriers as appropriate for the climate.

(continued next page)

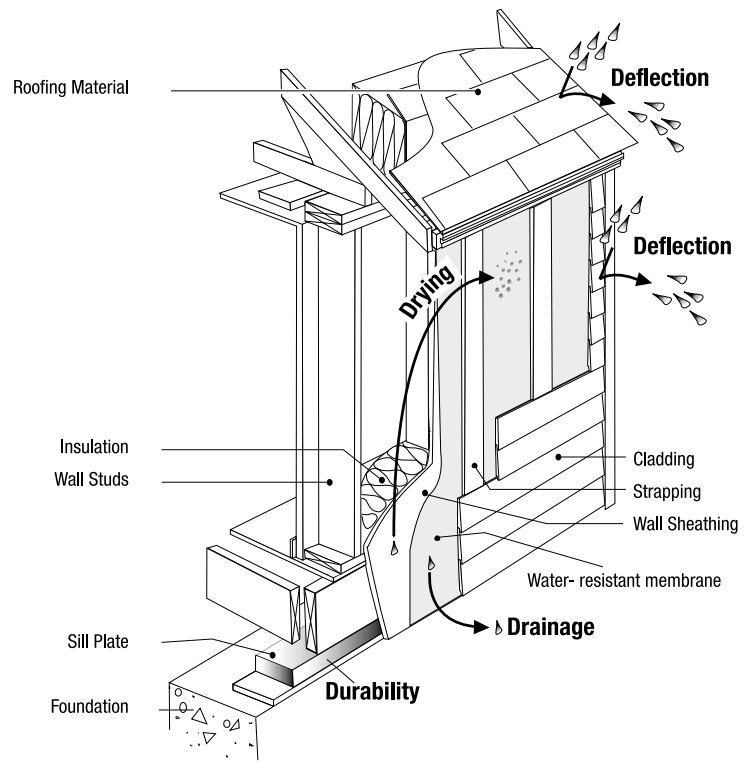

Best-practice wall design for a rainy climate uses all of the “4Ds” for moisture control. **Deflection** is the first line of defense, with most rainwater never getting past a good wall and roof skin. The cavity created by strapping behind the cladding also helps inhibit rain penetration by reducing the pressure forces that can drive rain through gaps in the skin. The small amount of water that may get past the cladding is handled by a **Drainage** path, as in the “rainscreen” design shown here, where liquid water in the cavity can flow quickly and unobstructed along the water-resistant membrane to an exit point from the wall. If water in the cavity moves beyond the water-resistant membrane, then the wood sheathing and studs can get wet and must be permitted to **Dry** to the outside of the wall — the liquid water in the wood is evaporated to vapour and passes through the outer layers of the wall, provided they are built properly to maintain vapour permeability. Only a very small amount of water can be shed by a wall through drying, therefore deflection and drainage are the primary mechanisms for protecting a wall from moisture. Finally, for parts of construction that have a high risk of staying wet, **Durable** materials such as preservative-treated wood should be selected. Cladding, shingles and sill plates are good examples of appropriate applications for treated wood.

Making a durable wood building

(continued from previous page)

Sometimes wood is expected to get wet — in decks, fences and roof shingles, for example. Species traditionally chosen for such applications — including western red cedar (*Thuja plicata*), yellow cypress (*Chamaecyparis nootkatensis*), and eastern white cedar (*Thuja occidentalis*) — contain natural substances that inhibit or even kill fungi: thus they are naturally more durable. Other wood species may still be used in wet applications if they are protected against decay with a preservative. Wood species including spruce, pine and fir are generally treated with a special process that forces fungi-inhibiting chemicals into the wood under pressure. Pressure-treated wood is non-toxic to humans, has outstanding durability, and has been used in decks, fences and many other exposed applications for generations. It's been around a long time, it's safe, and it works.



Forintek is Canada's wood products research institute. Established as a private, not-for profit corporation in 1979, Forintek is an amalgamation of two former public laboratories whose history dates back to 1913. To this day, Forintek continues to provide leading-edge technical support to the solid wood products industry. As part of its broad program, Forintek is a major North American supplier of information on treatment technologies and durability performance of wood. Visit www.forintek.ca.



Canada

Canada Mortgage and Housing Corporation is the Federal government's housing agency. For over 50 years, CMHC has been helping provide Canadians with housing quality, affordability and choice. CMHC is also the Canadian housing industry's export partner, bringing Canadian expertise to foreign markets. In addition, CMHC is Canada's largest publisher of housing information. Visit www.cmhc-schl.gc.ca.

For more information

For a good web site on durable wood construction, including design guidelines, case studies, aspects of treated wood, and other technical background, go to: www.durable-wood.com

Best Practice Guide, Wood Frame Envelopes is a general design resource, and *Best Practice Guide, Wood Frame Envelopes in the Coastal Climate of British Columbia* has additional design guidance specific to a temperate, rainy climate. Both are available from Canada Mortgage and Housing Corporation, telephone 1-800-668-2642 (in Canada), 613-748-2003 outside Canada, or visit www.cmhc-schl.gc.ca

For help in designing to accommodate the natural shrinking and swelling of wood, use the DeltaCALC software available from the web site of the Canadian Wood Council: www.cwc.ca

© 2002 Forintek Canada Corp. and Canada Mortgage and Housing Corporation.

This document is also available in French.
Document revised — September 2002