

PLAN SECTION A

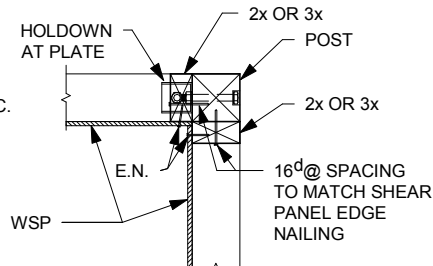

PLAN SECTION E

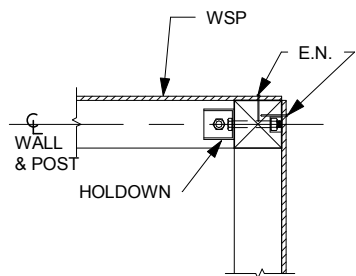

PLAN SECTION B

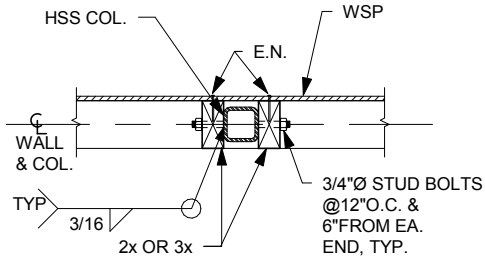

PLAN SECTION F

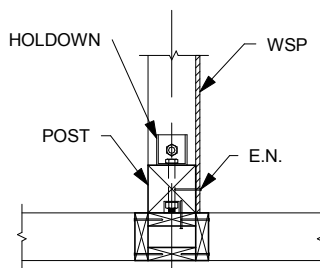

PLAN SECTION C

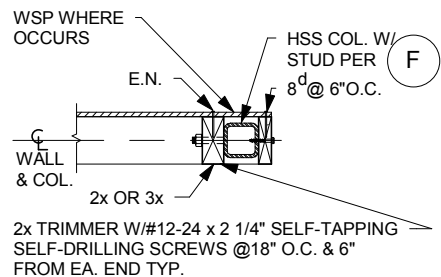

PLAN SECTION G

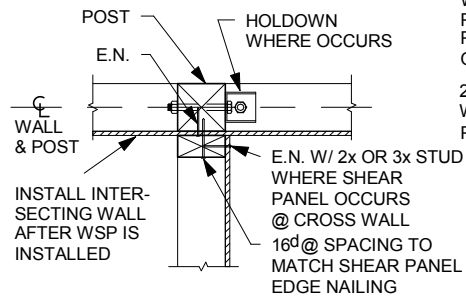

PLAN SECTION D

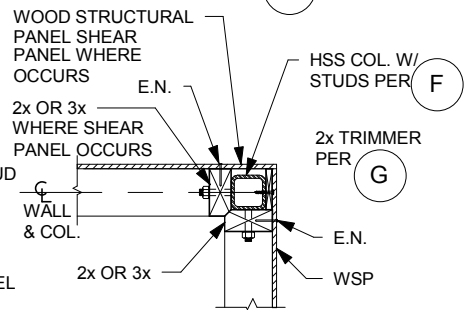

PLAN SECTION H

NOTE: WSP = WOOD STRUCTURAL PANEL